

Even at low wind speed classifications such as non-cyclonic N2, sheet roofed houses will have net wind uplift forces that need to be tied-down with specific tie-down connections. As site wind classifications increase all roof types require specific tie-down. Wind uplift forces increase in proportion to the square of the velocity of the wind so, for example, a site with a wind velocity of 61m/s (C2) will have 50% higher uplift forces than a 50m/s (C1) site. Getting every required tie-down connection right is critical as failure of one link in the tie-down chain can lead to loss of a whole roof in a wind event.

This data sheet addresses common issues with tie-down and support that are regularly seen on building sites. Refer also to TDS 26 - Truss Installation and AS 1684 Part 2 and 3 for more detailed design information.

MACHINE NAILING

Care needs to be taken when using machine driven nails through joist hangers, framing anchors and tie-down straps etc.

All connector manufacturers have specific recommendations on acceptable practices where machine nails are used. These cover minimum edge distances, types and sizes of nails as well as number of nails which usually have to be increased over the supplied standard nails to account for their smaller diameters.

Following extensive consultation with industry, The QBCC recently revised and released their requirements for use of gun nails in metal tie-down connections. This advice which can be accessed at the link below states that only hand nails are to be used in some connectors such as Triple Grips, Multi Grips and Universal Grips.

<http://www.qbcc.qld.gov.au/blog/tradie-talk/update-gun-nailing-tie%E2%80%93connectors>

This advice also provides guidance on acceptable installation practices for where machine driven nails can be used and the nail location requirements. See Figure 1.

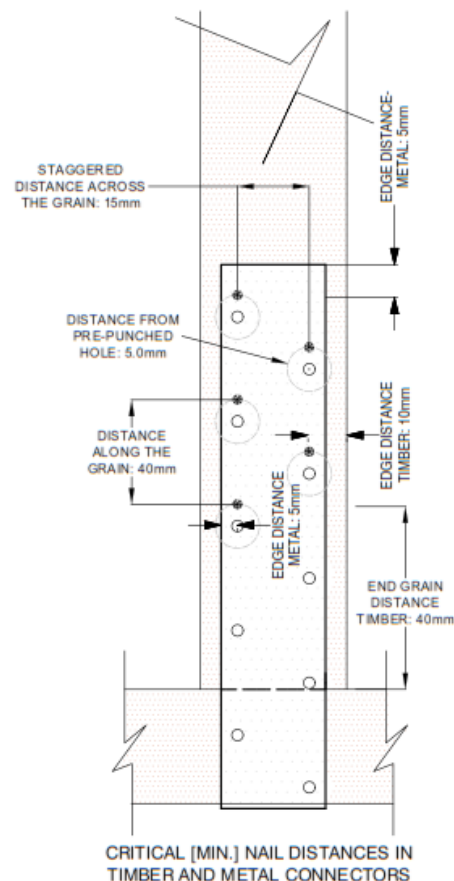

Notes:

1. Nail must not be in line with holes across the width of strap as it reduces steel x-section area. Nails to be installed staggered as seen in the sketch.
2. Tool pressure must be adjusted to drive the nails home completely but not over-driven causing the metal to tear
3. Recommendations are for hardened flat head 30mm x 2.5mmØ nails
4. Recommendations are for softwood connections. Timbers prone to splitting must be connected using alternate suitable connectors.

Figure 1. – Machine nail location requirements (Source Pryda/QBCC)



Photograph 1 - Inappropriate practices as nails are too close to strap edge, too close to pre-punched holes and even doubled up. Strap should also have been installed on the inside of frame to enable strap nailing direct to lintel without bending the strap



Photograph 2 - A structurally inadequate and incorrectly installed multi-grip. Nails too close to each other and edge of metal and also, too close to top edge of top plate

WASHERS FOR COACH SCREWS, BOLTS AND TIE-DOWN RODS

The timber framing code, AS 1684 specifies the minimum washer sizes required for coach screws, bolts and tie-down rod connections. The size and thickness of a washer plays an important part in the specified strengths of these connections and the correct size must be used to achieve the connection capacities given in the Standard. Cup-head bolts with standard washers or large washers, do not achieve the same strength as their hex-head equivalents. Table 1 gives the minimum washer sizes required.

TABLE 1: WASHER SIZES

Coach screw, bolt, tie-down rod Dia. (mm)	Washer Size (mm)
Cup-head bolts	Standard washers
M10	38 x 38 x 2.0
M12	50 x 50 x 3.0
M16	65 x 65 x 5.0

TIE-DOWN OF ROOFING SYSTEMS

Tile roofs

Cyclones Larry and Yasi revealed deficiencies in fixing methods for tile roofs. This resulted in new requirements (N4, C2 and C3) that require every tile (whole, cut, ridge and hip) to be mechanically fixed with screws, clips or other mechanical method as recommended by the manufacturer. Bedding compounds are no longer permitted for tying down tiles in these high wind regions.



Photograph 3 - Inadequately fixed tiles dislodged after high wind event

Sheet roofs

In cyclonic regions, the NCC – BCA requires sheet metal roofing systems (sheeting, sheet fixings, battens and batten fixings) to comply with the 'high-low-high' cyclic loading pressure sequence specified. This effectively requires manufacturers to have their products tested and certified by an appropriate body such as the Cyclone Testing Station in Townsville. Manufacturer's recommendations for installation of roofing systems must be strictly followed including:

- special requirements (closer batten spacing, more fixings etc.) for high local pressure areas close to roof edges, ridges and hips.
- Number and location of batten screws in metal battens
- Minimum steel thickness of metal battens (0.75 mm)



Photograph 4 – Roof sheeting 'blown' off due to inadequate fixing of the sheeting to the battens

Battens to Trusses/Rafters

Special attention should be paid to the connection of battens to rafters/trusses particularly at high local pressure areas such as hips. If these connection points are deficient it can result in roofs peeling off.

The joining of battens at supports can be achieved by the methods given in Figure 1, and an acceptable method of joining battens between supporting trusses/rafters is shown in Figure 2.

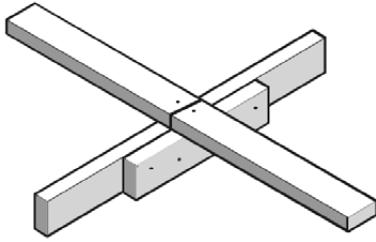

(a) Butt-joint with block fixed to side of rafter/truss

Figure 2 – Joining battens at supports

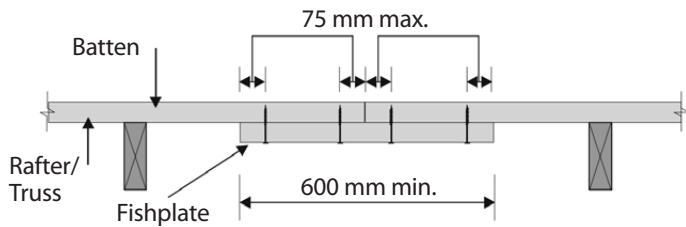
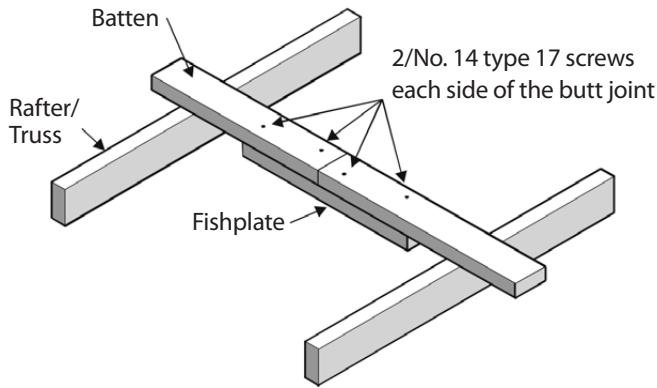

Figure 3 – Joining battens between supports



Photograph 5 – Roof sheeting and battens have failed due to nailed batten fixing where screws should have been used

TRUSS SUPPORT AND TIE-DOWN

Supports

Trusses must be supported (and tied down) at specified points, which unless specially designed, will occur at heels and at panel points on the bottom chords. Particular care should be taken to ensure this occurs with cantilevered trusses and long span or girder trusses that may be designed to also have internal support points.



Photograph 6 – Girder truss incorrectly supported by an offset wall

Truss/rafter tie-down

One of the most critical links in the tie-down chain is the connection of trusses/rafters to top plates, wall frames or direct to the floor frame or concrete slab.

This is particularly so for girder trusses which in some cases (very high uplift loads) may require direct tie-down of the truss to the floor or slab with full length cyclone rods and a metal angle or similar connecting the rod to the truss.

Attention also needs to be given to hip ends to ensure hip trusses, saddle trusses and jack trusses are correctly tied in to truncated girder and girder trusses.



Photograph 7 – Double straps connecting girder truss to top plate and jamb studs (strap to jamb stud should have been centrally located on stud). Cyclone rod correctly located within 100 mm of truss tie-down



Photograph 8 – Inadequate connection of jack and hip trusses to girder truss in a C2 site

Detail E2 - Jack Truss to Hip Truss
(maximum jack station 2400mm)

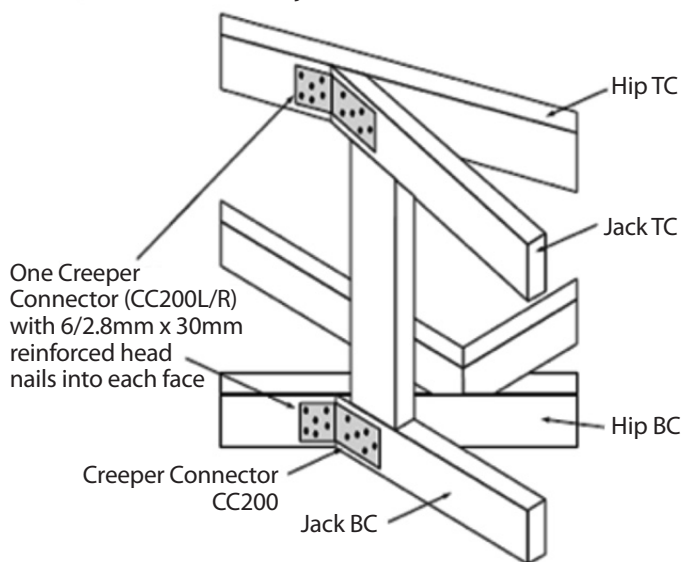

Figure 4 – Typical jack to hip truss connection as specified in AS 4440 for N4, C2 and C3 Wind Classifications

TIE-DOWN AT OPENINGS

Over openings

For N2 sheet roofs and all sheet and tile roofs N3 and greater, top plates will have net uplift forces applied to them where trusses/rafters are connected directly to the top plate and not directly to the floor frame or slab via anchor rods. The top plates will therefore be required to be able to span (bending in an upward direction) between top plate tie-down points installed in the wall frame to resist uplift.

At openings, tie-down of the top plates can only occur at the sides of the opening. Therefore, trusses and rafters that are tied down over the opening are required to be tied to the lintel to transfer uplift loads back to the tie-down points either side of the opening. Top plates, typically being a double standard plate are not capable of spanning any great distance (i.e. openings typically greater than 1200 mm), in

uplift, between tie-down points either side of openings.

For these situations, options for tying trusses/rafters to lintels over openings include:

- Tie trusses/rafters to top plate and then within 100 mm of this tie top plates to lintels with strap, bolts or similar
- Tie trusses/rafters direct to lintel.



Photograph 9 – Incorrect practice for tying down over openings as top plates not tied to lintel



Photograph 10 – Truss tied direct to top plate and lintel, but strap bent through too great an angle to be effective

[Note: The truss to the far RHS is tied to a block nailed to the lintel. This would be satisfactory as the strap is not bent as long as block had sufficient nails into lintel.]

At sides of openings

A practice that has mistakenly been considered acceptable (mainly in non-cyclonic areas) has been the use of plywood at sides of openings to effect tie-down of top plates to bottom plates. Plywood bracing can be used for tie-down in the general run of wall frames within prescribed limits, but is not suitable for tie-down at sides of openings because at least 300 mm of ply (top plate to bottom plate) is required either side of the truss/rafter being tied down at the side of the opening and in most circumstances this cannot be achieved. Sides of openings must be tied down by other means.



Photograph 11 – Plywood cannot be used to effect tie-down at sides of openings as the trusses highlighted above must have 300 mm min of ply to the right and left side respectively

BOTTOM PLATES TO SLABS

Bottom plates that overhang slab edges present serious challenges in respect of achieving compliant tie-down of the plates to the slab. Where bottom plates overhang slab edges by more than 10 mm it is almost impossible to tie plates down using conventional mechanical or chemical anchors to achieve the minimum slab edge distances required by fastener manufacturers. As well as impacting tie-down, the fixings required at the ends of sheet bracing walls will also be compromised.

Other issues that may also be affected include:-

- Maintaining minimum cavity clearances in masonry veneer construction
- Integrity of termite management system, and
- Provision of adequate support for gravity loads.



Photograph 12 – Structural integrity totally compromised by excessive bottom plate overhangs



Photograph 13 – Nominal bottom plate connection compromised by excessive plate overhang

BEAMS TO POSTS

Achieving satisfactory beam to post connections for both tie-down and gravity loads, particularly where beams meet at or are joined at supports, requires consideration of the following:-

- Achieving adequate bearing support
- Maintaining minimum bolt or screw end and edge distances, and
- Maintaining minimum timber thicknesses.

The various beam to post connection details given in the timber framing code AS 1684, specify these minimum requirements. Some examples of these are given in Figures 4 and 5.

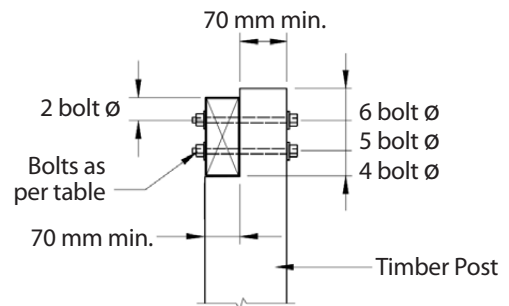

Figure 5 – Example 1 - 1684 typical beam to post detail

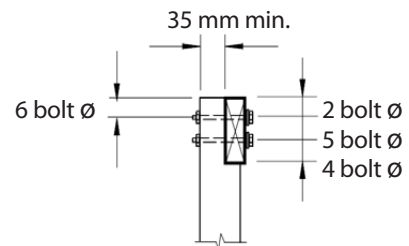

Figure 6 - Example 2 - 1684 typical beam to post detail

As a general guide, unless specifically nominated by AS 1684, the required end distances for fasteners are:-

- Bolts - 5 x bolt diameter
- Screws - 10 x screw diameter
- Nails - 20 x nail diameter
(10 x dia. if nails holes are pre-bored)



Photograph 14 – Posts over checked, bolted connection would not achieve any tie-down capacity



Photograph 15 – Minimum bolt end distances less than required to achieve uplift capacity. Also, unseasoned timber packer used is not suitable due to shrinkage



Photograph 16 – Intersecting verandah beams. The LH beam has inadequate bearing and tie-down capacity

ATTACHING PERGOLAS AND CARPORTS TO A HOUSE

Pergolas/carports can be attached to an existing house provided certain conditions and issues are checked and addressed. These include:-

- Ensuring the wall frame and tie-down connections of the house can carry the additional load contributed by the pergola/carport, including the uplift
- Where attaching to the fascia/eaves, ensuring the truss/rafter overhang size is structurally adequate for the additional uplift and gravity loads
- Timber fascias shall be minimum 190 x 25 mm.
- Metal fascias shall be stiffened with 150 x 50 mm nogging and 100 x 38 mm ledger as shown in Figure 6 and
- Pergola or carport rafters may be notched up to 1/3 their depth (max).

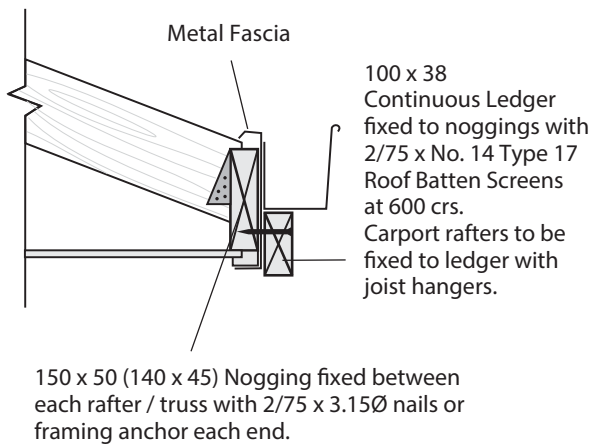

Figure 7 – Strengthening metal fascias to attach pergola rafters

For more detailed advice including member sizes and specific connection details, refer to Timber Queensland Technical Data Sheet, TDS 19 – *Pergolas and Carports*.

ACKNOWLEDGEMENTS

The contributions from the Queensland Building and Construction Commission, James Cook University Cyclone Testing Station and Lex Somerville, BMCC Services that assisted in the development of this Technical Data Sheet are gratefully acknowledged.

FURTHER INFORMATION

For more detailed and valuable information and advice on tie-down in high wind areas, including post wind event survey findings and outcomes, visit the Cyclone Testing Station website at: <http://www.jcu.edu.au/cts/>



**TIMBER
QUEENSLAND**
We build Queensland

Timber Queensland Limited

ACN 092 686 756 | ABN 50 092 686 756

30 Boothby Street, Kedron
Brisbane Queensland 4031

Phone (07) 3358 7900

Fax (07) 3358 7999

PO Box 231, Kedron Qld 4031

admin@timberqueensland.com.au

www.timberqueensland.com.au

Whilst every effort is made to ensure the accuracy of advice given, Timber Queensland Limited cannot accept liability for loss or damage arising from the use of the information supplied.