

pryda

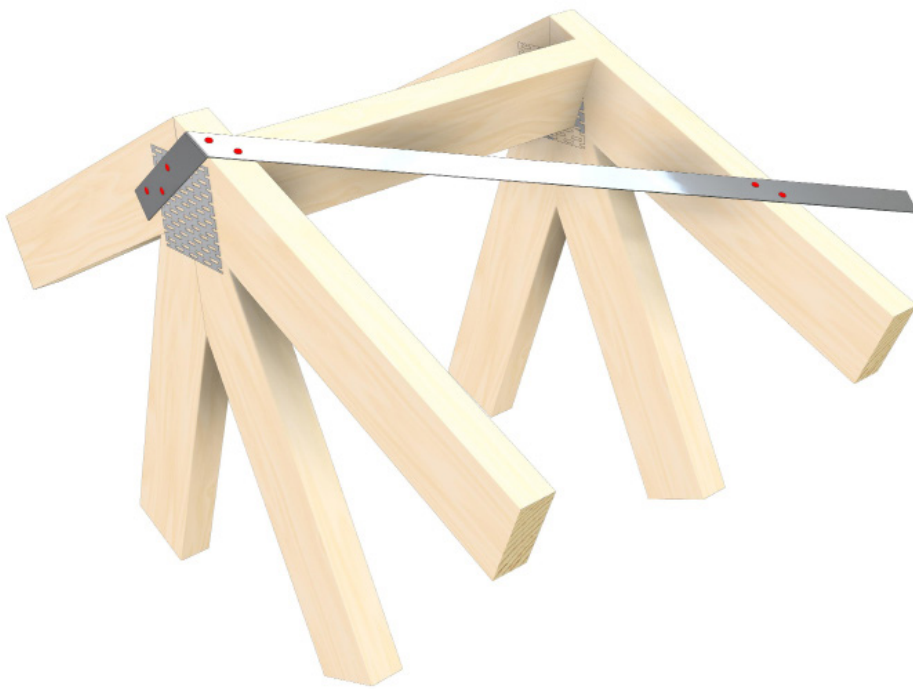

DESIGN GUIDE

BRACING

2022

BRACING - DESIGN GUIDE

TABLE OF CONTENTS

ESSENTIAL NOTES	2
GENERAL NOTES	3
ANGLE BRACE	4
PRYDA STRAP BRACE & TENSIONERS	9
SPEEDBRACE	11
STRAP BRACE	16
NARROW BRACING UNITS	21
TECHNICAL INFORMATION	22
PRYDA SHEAR CONNECTORS (PSC)	24
TIE-DOWN ANCHORS	27
APPENDIX	28

Product Information Updates

Information contained in this product guide is subject to change.

The latest updates are available from www.pryda.com.au.

ESSENTIAL NOTES

Introduction

The information in this Product Guide is provided for use in Australia by architects, engineers, building designers, builders and others. It is based upon the following criteria:

1. **No Substitution:** The products covered by or recommended in this guide must not be substituted with other products.
2. **Design Capacity Basis:** See Codes & Standards following.
3. **Supporting Constructions:** Constructions using Pryda products must be built in accordance with the NCC (BCA) or an appropriate Australian Standard. *Note: This includes appropriate corrosion protection- See Corrosion Protection following.*
4. **Correct Installation:** Installation of Pryda products must be strictly in accordance with the instructions in this guide.
5. **Current Guide Version Used:** The current version of this guide, including any amendments or additions, must be used. Users are advised to check the Pryda website, www.pryda.com.au, on a regular basis for the most current design guides.

Codes & Standards

Product design capacities in this guide have been derived from:

- (a) Results of laboratory tests carried out by or for Pryda Australia
- (b) Engineering computations in accordance with the relevant Australian Standards, ie:
 - AS1720.1-2010 Timber Structures. Part 1: Design Methods.
 - AS/NZS1170 series Structural Design Actions.
 - AS4055-2006 Wind Loads for Housing.

Design capacities tabulated in this guide apply directly for **Category 1** joints. For all other joints, reduce design capacities by using the factors as specified in *General Notes (if applicable)*. Design capacities are related to the **Joint Group** of the timber as defined in AS1720 and AS1684. If the Joint Group of timber members joined together varies, the lower group must be assumed for design, for example, JD5 is lower than JD4.

Definitions

Special terms used in this guide are as defined in Australian Standards, including:

Design Capacity: The maximum Limit State Design load (aka "action") which the product can safely support under the specified load condition, eg, 1.2G + 1.5Q (dead+roof live). *See General Notes for details (if applicable).*

Joint Group: Classification of a timber according to its fastener-holding capacity. *See General Notes for details (if applicable).*

Corrosion Protection

Most Pryda products are manufactured using Z275 light-gauge steel, having zinc coating of 275 gsm (total weight). This protection is adequate only for INTERNAL applications in most corrosive environments, except areas that are classified as heavy industrial or those subject to high humidity (eg, enclosed swimming pools). Under these circumstances, seek advice from experts as special protection will be required. *Note: INTERNAL areas are those within the building envelope that are kept permanently dry.*

AS1684.2-2010 and AS1684.3-2010, Australian Standards for Residential Timber Frame Construction stipulate a minimum Z275 steel for all sheet metal products used in an internal environment.

In areas outside the building envelope that are exposed to repeated wetting (EXTERNAL areas), Pryda's stainless steel products or equivalent should be considered. Some alternatives include hot dip galvanised or powder coated steel, which are not supplied by Pryda. For more detailed information, read Pryda's Technical Update on *Corrosion Resistance of Pryda Products* or contact a Pryda office.

Product Certification

Pryda Australia warrants:

- Products in this guide are free from defects in the material and manufacturing
- Design capacities are in accordance with test results or current, relevant Australian Standards and the Building Code of Australia.
- Pryda products are structurally adequate provided they are designed, installed and used completely in accordance with this guide.

This warranty applies to:

- Products in this guide.
- Products used in the specified applications and not damaged after manufacture and supply.
- Joints free from wood splitting, decay or other timber defects at the joint or within 150 mm of the joint.

Instructions for Installation

These notes are provided to ensure proper installation.

1. All fasteners used must be manufactured by reputable companies and be of structural quality.
2. Connectors must not be installed on timber which is split before or during installation. If the timber is likely to split as fasteners are driven, fastener holes must be pre-drilled.
3. Do not overload the joints during construction or in service.
4. Hole diameter for bolts in seasoned timber must not be more than 1.0 mm larger than the bolt diameter to achieve a snug-tight connection. Specified washers must be installed against the timber face.
5. Use proper safety equipment and due care in installing these connectors.
6. Any gaps in joints between the timber members must not exceed 3 mm.
7. Do not over-tighten screws.

GENERAL NOTES

Timber Joint Groups

For more than 30 years, Pryda bracing products have been developed to be structurally sound and cost effective for the bracing of roofs, walls, floors and other parts of timber framed buildings. They are designed to meet code bracing requirements and have been laboratory tested to assure their strength.

Specification for Pryda Bracing

All Pryda bracings are manufactured from G300 -Z275 ZincForm® steel or equivalent for high strength and corrosion resistance in normal, interior uses. Higher levels of zinc coating or epoxy paints are also available to suit use in corrosive environments such as near the sea front.

Product details are tabulated in the Pryda Price List and Pryda Catalogue publications.

Which Bracing to Use?

Collectively, Pryda bracings are suited to all common bracing uses in timber framing.

APPLICATION	SUITABLE BRACING
Floor joists	Strap Brace
Walls	Angle Brace, Strap Brace, Speedbrace
Roof Trusses	Speedbrace*, Strap Brace,

* Recommended for this use.

For bracing of walls in accordance with AS 1684 Residential Timber-framed Construction, see the Pryda Wall Bracing Unit Construction Guide available in this document (from page 8 onwards).

A guide to bracing roof trusses is included in AS4440:2004 Installation of Nailplated Timber Trusses. Speedbrace is usually preferred to Strap Brace for this use because of its special advantages.

Pryda bracings can also be used for some uncommon applications, depending on the design strength required. For this reason, Design Capacities are included in this publication.

Pryda Timber Connector Nails

For fixing of all Pryda bracings, it is essential to use galvanised Pryda Timber Connector Nails, ie, the special 35 x 3.15mm nails developed by Pryda specifically for fixing of our products. Laboratory strength testing has shown that clouts are not adequate for this purpose as their heads may pop off under less than design load.

Machine Driven Nail Use

Where appropriate, 32 x 2.3 mm Duo-Fast C SHEG (ie, screw hardened electro galvanized) machine driven nails (code D40810) or equivalent may be used instead of the specified 35 x 3.15 mm Pryda Timber Connector Nails to fix Pryda connectors provided that:

- One additional nail than specified in the bracing details (eg, 2 instead of 1, 3 instead of 2, 5 instead of 4 etc.)
- Machine driven nails are driven at nail spacings and edge distances similar to the hole pattern, ensuring that these nails are not driven into the holes or located not closer than 5mm from the edge of a hole.

Note: Extreme care must be taken when using machine driven nails as the prevailing installation practices tend to inhibit compliance with the above requirements.

Some of other pneumatic coil screw hardened nails considered equivalent to Duo-Fast D40810 are Paslode 32 x 2.5 mm (B25110), Duo-Fast 32 x 2.5 mm (D41060), Paslode 40 x 2.5 mm (B25125) and Duo-Fast 40 x 2.6 mm (D42360).

Fixing into Steel Supporting Structure

Pryda products can be fixed into steel using Buildex TekTM screws or similar.

Information on fixing Pryda bracing products to steel framing is available in the publication titled Design Guide – Pryda Connectors for Steel Framing.

Material Thickness

All material thicknesses referred to in this guide are the total coated thickness. This includes the zinc coating thickness, which is typically around 0.04 mm for Z275 steel.

Installation

Good installation of bracings is most essential. Pryda recommendations as specified in this guide. Particularly important are:

Nailing: Keep the nails away from ends or edges of timber to assure good nailholding.

Brace Angle: Install the brace at an angle of between 40 and 50 degrees to the horizontal if possible. Otherwise, the minimum is 30 degrees, maximum 60 degrees.

Strap Tensioning: Ensure each length of Strap Brace has a Pryda Tensioner, properly tightened prior to nailing. Tension Speedbrace by hammering it flat over each stud and wall plate.

Angle Brace Slots: Don't overcut the slot (notch) for the brace as this will weaken the studs. 20 mm is the required maximum slot depth for both Mini and Maxi Brace.

As Mini Brace has a shorter leg (16 mm), the studs can be checked 3 mm so that the brace and nails are installed flush with the stud edge (pictured). Maxi Brace must not be checked (rebated) into the stud edge because the notch depth would then exceed the 20 mm maximum specified in AS1684.

ANGLE BRACE

FEATURES AND BENEFITS

EASY: No tensioning required and sits flat against the stud.

VERSATILE: Available in two specifications. The stronger angle brace, Maxi Brace requires one diagonal length to achieve an AS1684 Type A bracing unit. The smaller Mini Brace requires two lengths in two sections of wall but can be rebated into the stud for a completely flush finish ahead of plastering.

Note: Pryda Mini Brace 18 x 16 x 1.2mm is no longer available.

STRONG: Angled form makes Angle Brace the strongest Bracing option in compression.

SPECIFICATIONS

STEEL	G300
THICKNESS	1.2mm
CORROSION RESISTANCE	Z275
FASTENERS	Pryda Timber Connector Nails 35 x 3.15mm
LENGTHS	3.6, 4.2, 4.8m

Wall bracing solution that is strong in compression and tension.



AS1684 & NCC COMPLIANT

- Type A wall bracing unit as per AS1684-2010.

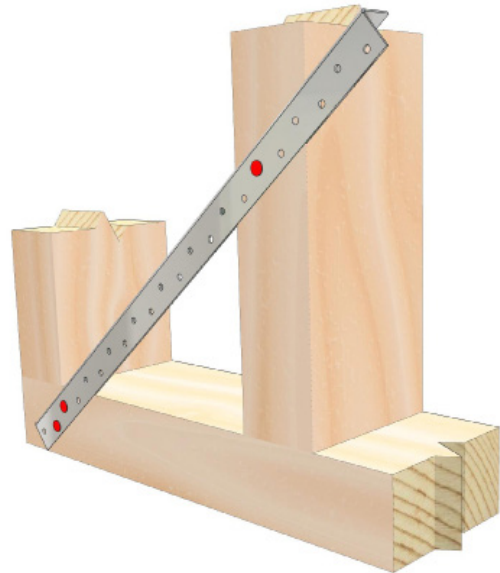

INSTALLATION – AS1684 TYPE A BRACING UNIT

ANGLE BRACE

PRODUCT CODE	MATERIAL	SIZE	LENGTH	QUANTITY	DESIGN TENSION CAPACITY (ΦNJ) KN	DESIGN COMPRESSION CAPACITY (ΦNJ) (KN)			
						450MM SPACINGS		600MM SPACINGS	
						0°	45°	0°	45°
MINI BRACE*									
MB36*	G300 Z275 Galvanised Steel	18 x 16 x 1.2mm	3.6m	100	7.8	N/A			
MB42*			4.2m						
MB48*			4.8m						
MAXI BRACE									
AB36	G300 Z275 Galvanised Steel	20 x 18 x 1.2mm	3.6m	100	9.5	3.7	2.6	2.7	1.9
AB42			4.2m						
AB48			4.8m						

Note: Pryda Mini Brace 18 x 16 x 1.2mm is no longer available, marked with *.

PRYDA TIMBER CONNECTOR NAILS

PRODUCT CODE	MATERIAL	SIZE	PACK CONFIGURATION	QUANTITY
OSNGB	Galvanised Steel	35 x 3.15mm Flat Head	500g cardboard packs x 10	5kg
OSNG			1kg cardboard packs x 10	10kg
TPOSNG			5kg Trade pack x 1	5kg
OSNBCI/SS	S316 Stainless Steel		500g clamshell pack x 1	500g

WALL BRACING UNITS – DETAILS

Note: Pryda Mini Brace 18 x 16 x 1.2mm is no longer available.

Mini Brace, Two Lengths, Type A Unit

This bracing unit comprises two sections of the same wall with Pryda Mini Brace braces in opposing diagonals, as shown below. These two wall sections are considered to work together. AS1684 has a maximum wall height of 3.0 m (except at gable or skillion ends). Design capacity of these units is 0.8 kN/m for wall heights up to 2.7 m and 0.72 kN/m for 3.0 m height. The table values given below are the total capacity from both wall sections and assumes that both wall sections are of equal length.

WALL HEIGHT	BRACING CAPACITY (KN) FOR BRACING LENGTH OF EACH WALL SECTION (M)									
(m)	1.8	1.9	2.0	2.1	2.2	2.3	2.4	2.5	2.6	2.7
2.7	2.7	2.9	3.0	3.2	3.3	3.5	3.6	3.8	3.9	4.1
3.0	2.4	2.6	2.7	2.8	3.0	3.1	3.2	3.4	3.5	3.6

Note: For walls higher than 2.7 m, reduce the bracing unit's capacity in inverse proportion to the wall height, eg, for 3.6 m walls, take $2.7/3.6 = 0.75$ times the capacity for 2.7 m height.

INSTALLATION – AS1684 TYPE A BRACING UNIT

Note: Pryda Mini Brace 18 x 16 x 1.2mm is no longer available.

RACKING CAPACITY	
0.8kN/m at up to 2.7m wall height	0.72 kN/m up to a maximum of 3.0m wall height.
	Requires two lengths of Mini Brace

STEP 1

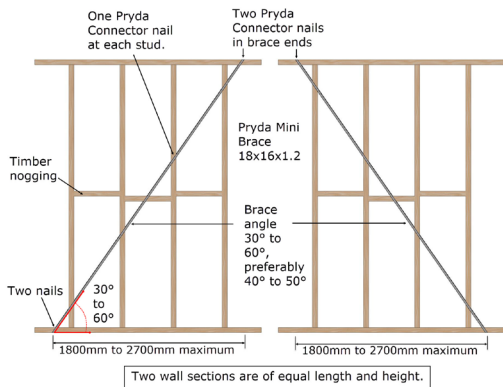

- Ensure wall is square and plumb
- Get two same lengths of Mini Brace lay in opposing diagonal directions as shown
- Keep the Mini Brace at an angle close to 45° (min 30° max 60°) and ensure the anchored ends of the brace are at least 150mm from the end of the top or bottom plates
- Use the Mini Brace as a ruler to draw a line across the frame to mark where you will slot into the studs

STEP 2

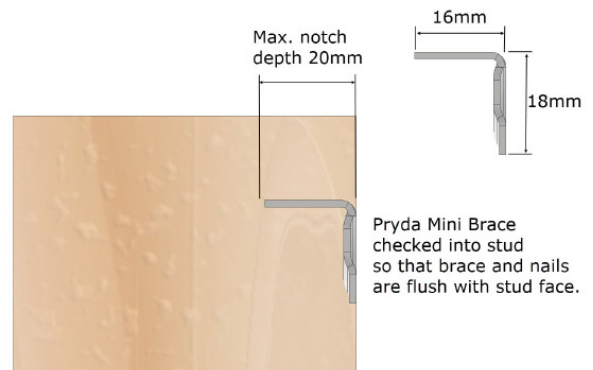

- Cut the slots where you have marked to a maximum depth of 20mm. Cut studs must be designed as notched.
- For a flush finish, check the studs to a max of 3mm

STEP 3

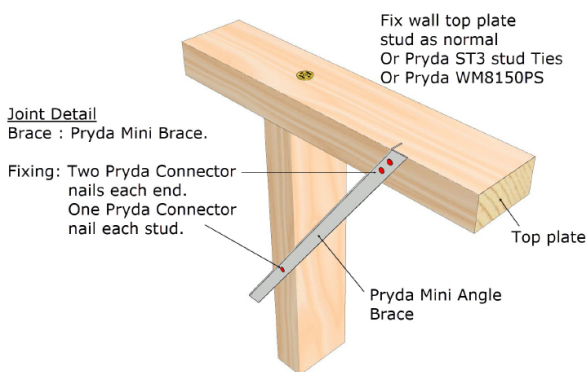

INSTALLATION – AS1684 TYPE A BRACING UNIT

Maxi Brace, One Length, Type A Unit (Racking Capacity = 1.5 kN/m)

This bracing unit comprises one section of the wall, with one brace of Pryda Maxi Brace, as shown below. Maximum wall height in AS1684 is 3.0 m (except at gable or skillion ends). Design capacity is 1.5 kN/m for wall heights up to 2.7 m and 1.35 kN/m for 3.0 m height.

WALL HEIGHT	BRACING CAPACITY (KN) FOR BRACING LENGTH (M)									
(m)	1.8	1.9	2.0	2.1	2.2	2.3	2.4	2.5	2.6	2.7
2.7	2.7	2.9	3.0	3.2	3.3	3.5	3.6	3.8	3.9	4.1
3.0	2.4	2.6	2.7	2.8	3.0	3.1	3.2	3.4	3.5	3.6

Note: For walls higher than 2.7 m, reduce the bracing unit's capacity in inverse proportion to the wall height, eg, for 3.6 m walls, take $2.7/3.6 = 0.75$ times the capacity for 2.7 m height. Use galvanised Pryda Timber Connector Nails (OSNG) size 35 x 3.15 mm.

RACKING CAPACITY	
0.8kN/m at up to 2.7m height	0.72 kN/m up to a maximum of 3.0m high
	One length of Maxi Brace

STEP 1

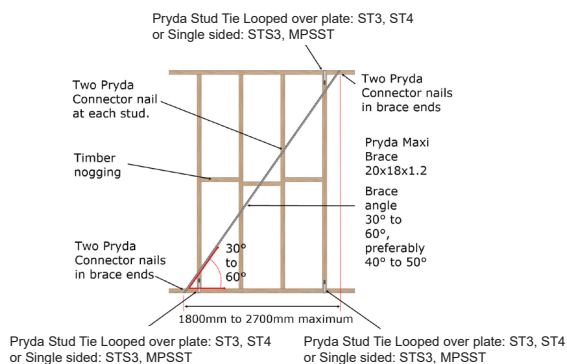

- Ensure wall is square and plumb
- Keep the Maxi Brace at an angle close to 45° (min 30° max 60°) and ensure the anchored ends of the brace are at least 150mm from the end of the top or bottom plates
- Use the Maxi Brace as a ruler to draw a line across the frame to mark where you will slot into the studs

STEP 2

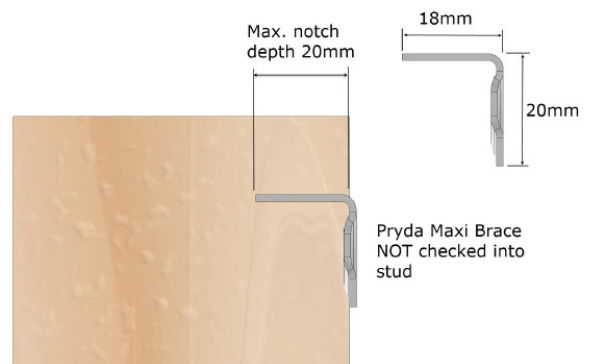

- Cut the slots where you have marked to a maximum depth of 20mm. Cut studs must be designed as notched
- Maxi Brace must not be checked into the stud edge because the notch depth would then exceed the 20mm maximum specified in AS1684

STEP 3

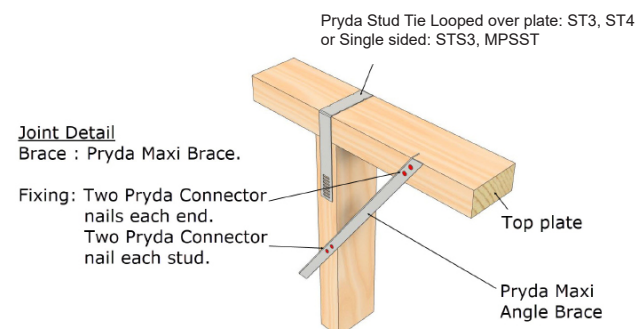

- Fit the lengths of Maxi Brace ensuring the vertical leg is facing down for safety as shown in Step 2.
- Fasten as per detail above

FASTENING ANGLE BRACE

BUILD WITH CONFIDENCE

WHERE POSSIBLE, HAND NAILING WITH PRYDA TIMBER CONNECTOR NAILS IS ALWAYS PREFERRED, WHY?

- Pryda Timber Connector Nails are forged in one piece, unlike clouts that are two pieces soldered together, meaning the head can pop off
- Pryda Nails are the correct diameter, ensuring a tight fit in prepunched holes = a stronger connection
- Design values and testing have all been conducted using Pryda Timber Connector Nails
- Hand hammered nails ensure correct nail positioning and drive depth (not driven too shallow or too deep)
- The corrosion resistance and material specification of Pryda Nails is known and can be certified

USING PASLODE MACHINE DRIVEN NAILS

Where appropriate, Paslode Machine Driven Nails listed below may be used instead of the specified 35 x 3.15mm Pryda Timber Connector Nails to fix Pryda connectors provided that:

- There is one additional nail per connection than specified in the bracing details (eg. 2 instead of 1, 3 instead of 2, 5 instead of 4 etc.)
- Machine driven nails are driven at nail spacings and edge distances similar to the hole pattern, ensuring that these nails are not:
 - Driven into the holes
 - Located not closer than 5mm from the edge of a hole
 - Grouped together
 - Within 10mm from the edge

Screw hardened, electro galvanised Paslode nails that are appropriate include:

- Duo-Fast C SHEG 32 x 2.3 (D40810)
- Paslode 32 x 2.5mm (B25110)
- Duo-Fast 32 x 2.5mm (D41060)
- Pas Coil 32 x 2.5 SHEG 2 Pack (B25250)
- Impulse 32 x 2.5 SHEG (B40020)



WRONG FIXING METHOD



CORRECT FIXING METHOD

ANGLE BRACE TIPS

1. For safety always install Angle Brace with the vertical leg facing downwards
2. Use the Angle Brace as a ruler to draw your cut line on
3. Angle Brace is pre-tensioned, so when bracing walls ensure everything is plumb and square prior to installing
4. Ensure nails are at least 10mm away from timber end or edges to prevent splitting
5. Keep wall bracing angles within 30° to 60° or the Brace will not be compliant
6. Do not overcut the slot, AS1684 specifies a maximum slot depth of 20mm



LOOKING FOR MORE DETAILED DESIGN VALUES?

SEE OUR BRACING DESIGN GUIDE AVAILABLE AT [PRYDA.COM.AU](https://www.pryda.com.au)

PRYDA STRAP BRACE & TENSIONERS



Nutsert

Wingnut & T Bolt

Uses & Advantages

Pryda Strap Brace with Tensioner, is an easy-to-use, flat strap steel bracing for roofs, walls, ceilings and floors. Strap Brace complies with the wall bracing rules of AS1684 Residential Timber-framed Construction and has excellent advantages, including:

- Saves on-site labour time as studs do not have to be notched. The unnotched studs can often be a smaller size and hence cheaper than notched studs.
- Available in long length coils for ease of handling and minimum wastage.
- Easily and quickly tensioned using the Strap Brace Tensioner - simply by driving the hex-head screw (nutsert option) or turning the wing nut (wingnut and t-bolt option).

Pryda Strap Brace is ideal for bracing applications where timber braces are not feasible because of their thickness or because timber can't be bent, eg, exposed beams or rafters, or trusses.

Sizes

Available sizes are:

PRODUCT CODE	ARTICLE AND SIZE
SB082/15 **	25 x 0.8 mm x 15 m coil
SB082/30 **	25 x 0.8 mm x 30 m coil
SB083/15	30 x 0.8 mm x 15 m coil
SB083/30	30 x 0.8 mm x 30 m coil
SB083/50	30 x 0.8 mm x 50 m coil
SB103/30	30 x 1.0 mm x 30 m coil
SB103/50	30 x 1.0 mm x 50 m coil
SB123/30	32 x 1.2 mm x 30 m coil
SB083/3.5	30 x 0.8 mm x 3.5 m lengths
SB083/3.5W-500	30 x 0.8 mm x 3.5 m lengths
SB083/4.0W-500	30 x 0.8 mm x 4.0 m lengths
GUS083/30	30 x 0.8 mm x 30 m lengths (unpunched strapping)

** SB082 product is not recommended for standard bracing units.

Strap Brace Tensioners

Bolt Specification: M6x30 T-bolt for SBT/SBT100 and M6x30 hex-head bolt for the nutsert type SBT30N /SBT100N.

PRODUCT CODE	PACKING
SBT	Includes wing nut, bolt and washer. 30 in carton (6 per pack x 5 packs)
SBT30N (nutsert)	Includes bolt. 30 in carton (6 per pack x 5 packs)
SBT100	Includes wing nut, bolt and washer. 100 per pack
SBT100N (nutsert)	Includes bolt. 100 per pack

Structural Performance

Pryda Strap Brace takes load in tension only and must therefore be used in pairs, in opposing diagonal directions. It must also be sufficiently tensioned to take the load without distortion of the frame.

Installation of Strap Brace

Floor Bracing

Pryda Strap Brace of any size, can be used as a herring-bone bracing for floor joists - as illustrated. A tensioner is not required for this use.

1. Fix the ends of both lengths of Strap Brace to the top and bottom of the first joist with two Pryda Timber Connector Nails per joint.
2. Pull each length of Strap Brace down from the top edge of the joist or up from the bottom onto the next joist. Tension using a screw driver or similar tool and fix with one Pryda Timber Connector Nail at each joist.

For floor systems with trusses, I-joists or deep beams, bracing is required for both: (a) stability during construction and (b) wind resistance during the life of the building. The bracing can be Pryda Strap Brace or Unpunched Strapping. It is to be fixed to the floor members and supporting structure with 35 x 3.15 mm Pryda Timber Connector Nails or power driven 2.5 mm or 2.87 mm nails (as shown).

Floor Bracing at External Wall

90x35 F5/MGP10 Continuous Tie. Nail fixed to truss end vertical with 2x2.8x75mm framing nails

Fix Strap Brace (SB123) with 2x3.15dia. x 35mm Pryda Connector Nails to Top chord.

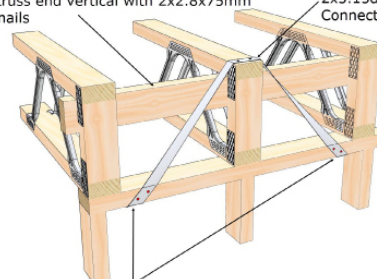

Wrap Pryda Brace (SB123) under Top Wall Plate and fix with 3.15dia. x 35mm Pryda Connector Nails. 2 nails to side and 4 nails to underside.

Max. Cross bracing 2700mm Centres

WALL BRACING

For details of bracing units see pages 9 to 11:

1. Make sure that the wall frame is close to square.
2. For Type B units, wrap the brace over the plate. Nail the end of the Strap Brace to the top plate within 150 mm of a stud using:
 - three Pryda Timber Connector Nails for Type A units or
 - four Pryda Timber Connector Nails for Type B units.
3. Lay the Strap Brace across the frame at an angle of 45 degrees approximately (30 to 60o) and with the unfixed end on the bottom plate at within 150 mm of a stud and allowing a length of strap to wrap around the plate. Cut the strap brace to length.
4. Straighten and partially tighten the Strap Brace by pulling it down onto the bottom plate. For Type B units, wrap the brace over the plate. Fix the end of the Strap Brace to the plate within 150 mm of a stud using Pryda Timber Connector Nails with:
 - two nails for Type A units or
 - four nails for Type B units
5. Fix the second length of Strap Brace in the same manner, diagonally opposing the first length.
6. Fit and tighten the tensioners on both braces, with the tensioner facing into the frame. Adjust the tensioner as required or until the brace is taut. Note: Do not use Strap Brace to plumb the frame.
7. Nail both braces to every stud crossed using ONE Pryda Timber Connector Nail for both Type A and Type B units.

The required minimum number of bracing units is specified in AS1684.

ROOF BRACING

To brace standard trusses, rafters or roof beams:

1. Use only SB123 Strap Brace (or Speedbrace) for roof bracing. Refer to AS4440-2004 or Pryda Truss Installation Guide to establish whether single or double Strap Brace is required based on roof span, pitch and wind speed.
2. Lay out diagonal opposing lengths of Strap Brace on top of the roof framing at a maximum angle of 30 degrees (measured on plan) to the ridge line. Braces are required on both sides of the ridge line and at both ends of the roof.
3. Fix Strap Brace at both ends by wrapping one end around the top wall plate and the other end around the rafter, roof beam or top chord of a truss at the ridge, and by nailing each end using the required number of Pryda Timber Connector Nails.
4. Fit and tighten the tensioners on both braces, with the tensioner facing down into the roof space. Adjust the tensioner as required or until the brace is taut. Note: Do not use Strap Brace to plumb the frame.
5. Nail both braces to every truss or rafter crossed using two Pryda Timber Connector Nails per crossing.

For more details of requirements for roof truss bracing refer to the Pryda's Roof Truss Installation Guide or to AS4440.

End Fixing Detail on Rafter Trusses

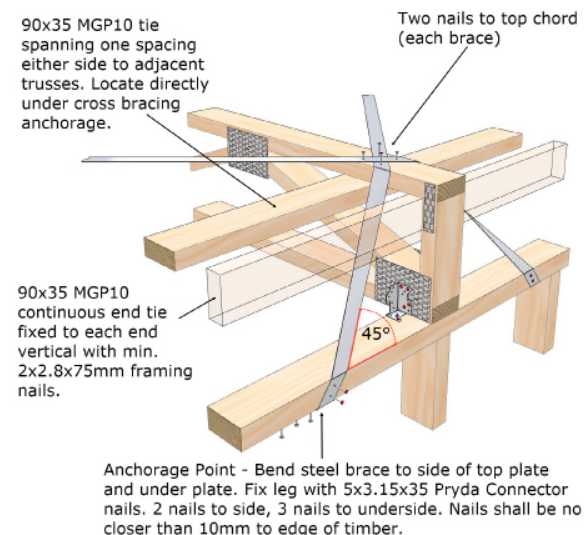

Refer to AS4440-2004 for Other Fixing Details.

SPEEDBRACE

FEATURES AND BENEFITS

FAST: Doesn't require tensioning or notching.

EASY: Comes in a variety of lengths suited to common applications just position and fix.

STRONG: 1.0mm G300 steel for consistent strength.

SPECIFICATIONS

STEEL	G300
THICKNESS	1.0mm
CORROSION RESISTANCE	Z275
FASTENERS	Pryda Timber Connector Nails 3.5 x 3.15mm
LENGTHS	4.0m and 6.0m

The quickest bracing option for roof trusses and walls.



AS1684 & AS4440 COMPLIANT

- Type A & B Wall Bracing units as per AS1684
- Roof bracing as per AS4440

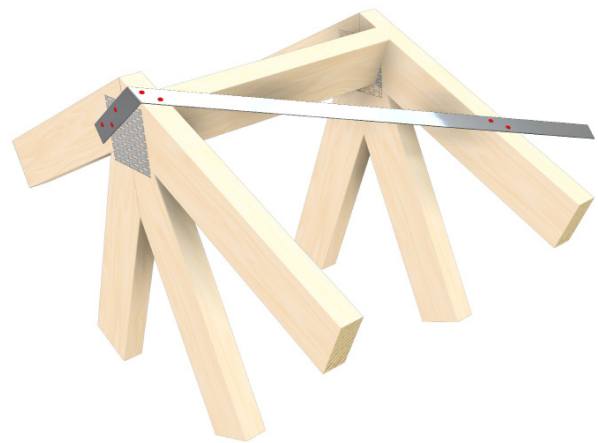

SPEEDBRACE

PRODUCT CODE	MATERIAL	SIZE	LENGTH	QUANTITY	SUITABLE FOR WALLS	SUITABLE FOR ROOFS	DESIGN TENSION CAPACITY (ΦNJ) KN
SDB36*	G300 Z275 Galvanised Steel	37x1.0mm	3.6m	100	✓	✓	8.7
SDB40			4.0m				
SDB50*			5.0m				
SDB60			6.0m	200			
SDB60/10			6.0m	100			

Tied in bundles of 10 lengths.

Note: The product marked with * is no longer available.

PRYDA TIMBER CONNECTOR NAILS

PRODUCT CODE	MATERIAL	SIZE	LENGTH	QUANTITY
OSNGB	Galvanised Steel	35 x 3.15mm Flat Head	500g cardboard packs x 10	5kg
OSNG			1kg cardboard packs x 10	10kg
TPOSNG			5kg Trade pack x 1	5kg
OSNBCI/SS	S316 Stainless Steel		500g clamshell pack x 1	500g

ADVANTAGES

Pryda Speedbrace is applied on top of the top chord, eliminating the difficulty of applying a brace to the underside of the chord as is necessary with conventional timber braces. The profile of Speedbrace allows it to be applied without the need for tensioners as the rib merely needs to be hammered flat where it crosses the timber members.

In addition, Speedbrace can be spliced easily and can be wrapped around members to provide sound and secure anchorage.

ROOF BRACING

Pryda Speedbrace can be installed as for Strap Brace, where Speedbrace crosses each truss it is hammered flat and nailed with two galvanised Pryda Timber Connector Nails at each truss crossed.

Pryda Speedbrace is spliced by overlapping lengths of brace hammering flat and nailing with the same number of galvanised Pryda Timber Connector Nails as is required at the top plate (see diagram below).

WALL BRACING

Pryda Speedbrace may also be used to brace wall frames.

IMPORTANT:

READ THIS DATASHEET IN CONJUNCTION WITH BRACING DESIGN GUIDE AND REFER TO ESSENTIAL NOTES AND GENERAL NOTES.

INSTALLATION

ROOF BRACING INSTALLATION

See your building plan for bracing layout, if you need assistance in the design of the roof bracing layout see AS4440:2004 Installation of Nailplated Timber Trusses as well as the Pryda Installation Guidelines for Timber Roof Trusses.

All trussed roofs require diagonal bracing to the top chords, which is typically at an angle of 30-45 degrees to the top plate, measured on plan.

Braces should be installed such that each main truss has a brace crossing it. Bracing is best located near the ends of buildings and will be installed on both sides of the ridge line. Some typical details are shown here:

END FIXING DETAIL

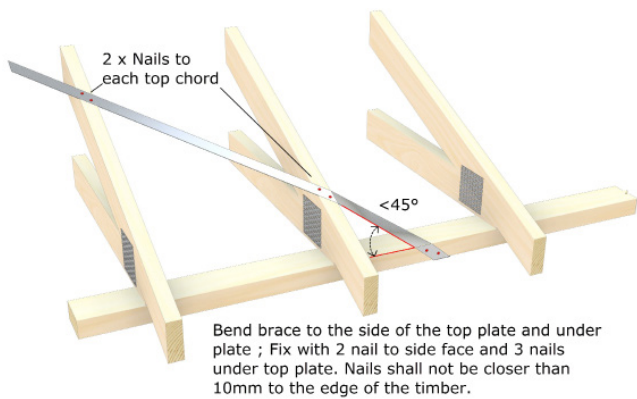

SPLICE DETAILS

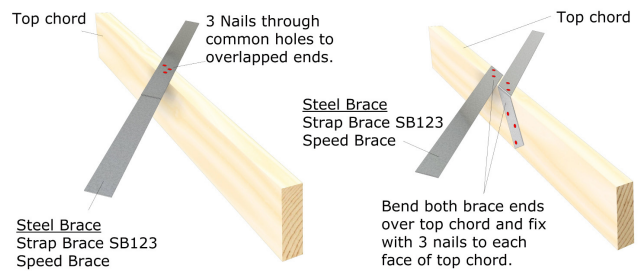

Flatten Speed Brace over nailing interface (top chord) before nailing.

(a) Lap Splice

(b) Wrap Around Splice

TYPICAL BRACING LAYOUT

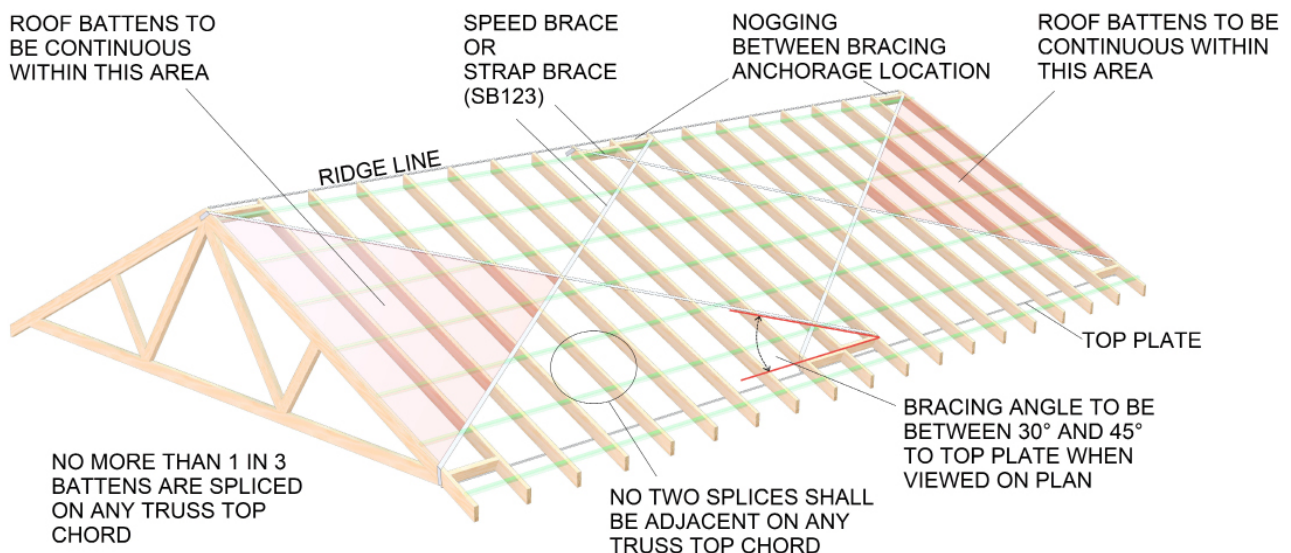

INSTALLATION

COMMON END FIXING DETAILS

Flatten Speed Brace over nailing interface before nailing.

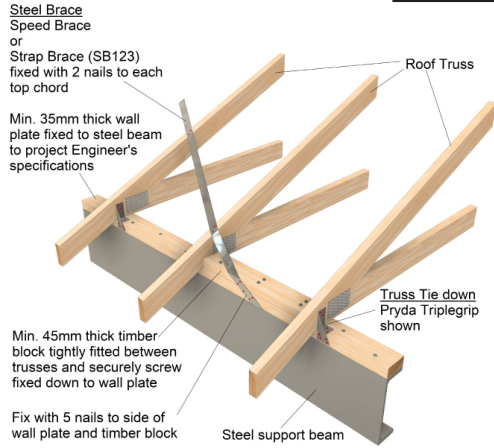

END FIXING DETAILS FOR STEEL BEAM

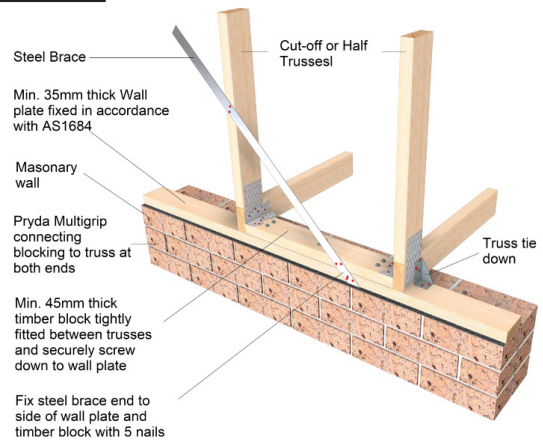

FIXING DETAILS FOR BRICKWALL PLATE

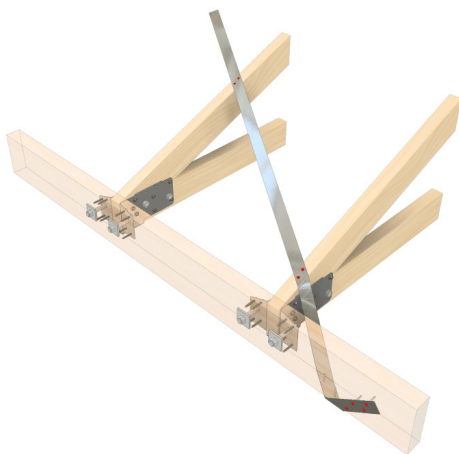

END FIXING DETAILS AT HEEL - TO GIRDER TRUSS

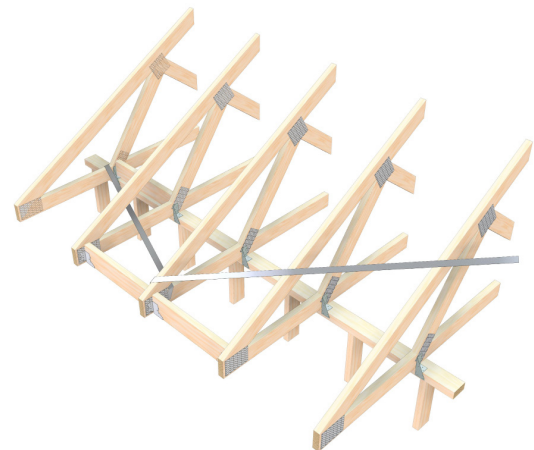

FIXING DETAILS FOR CANTILEVERS

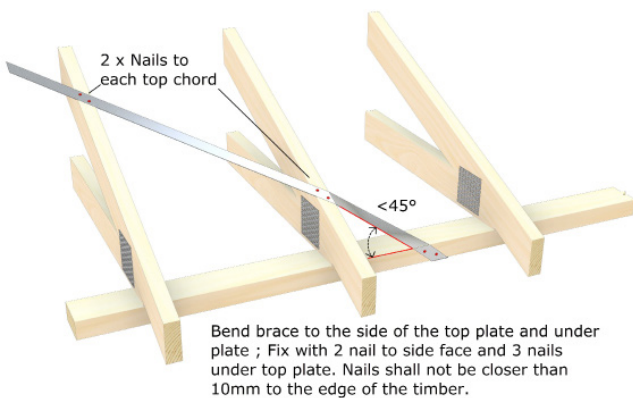

END FIXING DETAILS AT HEEL - TO TOP PLATE

SPEEDBRACE TIPS

1. Make sure the rib is hammered flat where it crosses the timber members
2. SpeedBrace self tensions as it is fixed, so when bracing walls ensure everything is plumb and square prior to installing. The SpeedBrace should still be taut when installed prior to nailing.
3. Ensure nails are at least 10mm away from timber end or edges to prevent splitting.
4. Keep wall bracing angles within 30° to 60° and roof angles between 30° to 45° (to top plate) or the Brace will not be compliant.
5. When lap splicing SpeedBrace, three product nails should be fixed through adjacent holes near the end of each brace and into the underlying timber. The end of each brace only needs to extend past the underlying timber by enough to fix the nails. As shown in AS4440 Figure 4.20.

FASTENING SPEEDBRACE

BUILD WITH CONFIDENCE

WHERE POSSIBLE, HAND NAILING WITH PRYDA TIMBER CONNECTOR NAILS IS ALWAYS PREFERRED, WHY?

- Pryda Timber Connector Nails are forged in one piece, unlike clouts that are two pieces soldered together, meaning the head can pop off
- Pryda Nails are the correct diameter, ensuring a tight fit in prepunched holes = a stronger connection
- Design values and testing have all been conducted using Pryda Timber Connector Nails
- Hand hammered nails ensure correct nail positioning and drive depth (not driven to shallow or too deep)
- The corrosion resistance and material specification of Pryda Nails is known and can be certified

WALL BRACING UNIT CONSTRUCTION GUIDE

Section 8 of AS1684:2010 – Residential Timber-Framed Construction specifies methods of determining the required minimum amount of permanent wall bracing, ie:

- Simplified method (Part 4 of AS 1684): The number of Type A bracing units included in each plan direction must comply with Table 8.2 – which depends on the overall size of the walls. Details of Type A bracing units are specified in Table 8.3 – and in this document.
- Other constructions (Part 2 or 3): The designer must either:
 - Calculate the design horizontal wind force (“total racking force” -kN) and the total capacity of the bracing included in each plan direction to resist this force, or
 - Look up the wind force in Appendix G of the code and ensure by calculation that the total capacity of the bracing exceeds this force.
 - Details of wall bracing units and their capacities (in kN/m) are specified in Table 8.18 – and in this document.

The “Simplified method” applies only to non-cyclonic wind zone N1 or N2 and to buildings of limited size – see Clause 1.6 of Part 4 of the code.

This guide provides full details of how bracing units (or “panels”) can be constructed in accordance with AS 1684 using Pryda Bracings, Stud Ties, Strap Nails and Pryda Timber Connector Nails. The details specified in AS1684 are based on the results of test on such units. Bracing capacities are for units with a lining such as plasterboard installed. During construction, additional temporary bracing may be required until the lining is fully installed. For information on the derivation of unit capacities, contact Standards Australia.



LOOKING FOR MORE DETAILED DESIGN VALUES?

SEE OUR BRACING DESIGN GUIDE AVAILABLE AT [PRYDA.COM.AU](https://www.pryda.com.au)

STRAP BRACE

FEATURES AND BENEFITS

VERSATILE: Can be cut to match any size or application, meaning you can do more, with less.

FAST: Slim profile means studs don't need to be checked, saving time and cost. Nutsert tensioner can be used with a drill to speed up tensioning.

EASY: Unlike Speed or Angle Brace, can be partially fastened but not tensioned allowing for plumb adjustment of wall frames prior to tensioning

SPECIFICATIONS

STEEL	G300
THICKNESS	0.8mm, 1.0mm or 1.2mm
CORROSION RESISTANCE	Z275 or G316L
FASTENERS	Pryda Timber Connector Nails 35 x 3.15mm
LENGTHS	3.5 & 4.5m strips 15, 30 & 50m rolls

Versatile and cost-effective bracing product for roofs, ceilings, walls and floors.



AS1684 & NCC COMPLIANT

- Minimum nett section of 15mm² for 0.8mm Strap Brace
- Minimum nett section of 21mm² for 1.0mm Strap Brace
- Minimum G300 Z275 galvanised steel

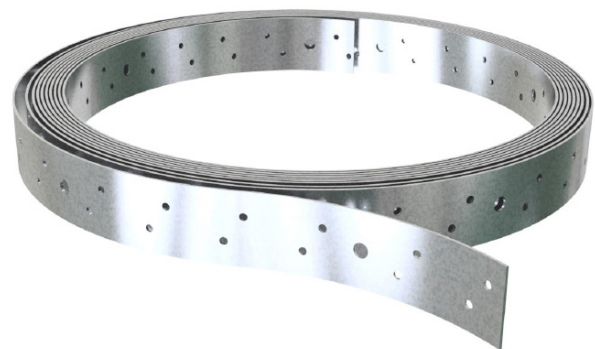

NUTSERT TENSIONER

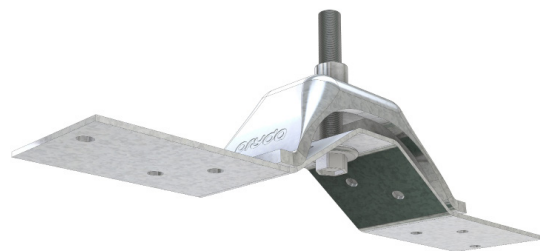

WING NUT AND T-BOLT TENSIONER



STRAP BRACE

PRODUCT CODE	MATERIAL	SIZE	LENGTH	QUANTITY	WALLS	ROOFS	FLOORS	DESIGN TENSION CAPACITY (ΦNJ) KN
SB083/15	G300 Z275 Galvanised Steel	30 x 0.8mm	15m	1 Roll	Type A (1.5 kN/m) & Type B with 20% reduced capacity (2.4 kN/m)	Not Suitable	✓	5.2
SB083/30			30m	1 Roll			✓	5.2
SB083/50			50m	1 Roll			✓	5.2
SB083/3.5W-500			3.5m	500 Lengths			✓	5.2
SB083/4.0W-500			4.0m	500 Lengths			✓	5.2
SB102/SS	G316L Stainless Steel	25 x 0.9mm	15m	1 Roll			✓	5.8
SB103/30	G300 Z275 Galvanised Steel	30 x 1.0mm	30m	1 Roll	Type A (1.5 kN/m) & Type B (3.0 kN/m)	Not Suitable*	✓	6.8
SB103/50			50m				✓	6.8
SB123/30		32 x 1.2mm	30m				✓	9.4

For more details on Type A & B Bracing units, refer to Australian Standard AS1684

*Can be used for Truss Tie Downs. Refer to AS1684 for permitted use and fixing details.

TENSIONERS

PRODUCT CODE	MATERIAL	SIZE	LENGTH	QUANTITY
SBT	G300 Z275 Galvanised Steel	Wing Nut Driven by hand	5 packs of 6 Tensioners	30
SBT100			10 packs of 10 Tensioners	100
SBT30N		Nutsert Driven by socket	5 packs of 6 Tensioners	30
SBT100N			10 packs of 10 Tensioners	100
SBT/SS	S316L Stainless Steel	Wing Nut Driven by hand	1	1

PRYDA TIMBER CONNECTOR NAILS

PRODUCT CODE	MATERIAL	SIZE	LENGTH	QUANTITY
OSNGB	Galvanised Steel	35 x 3.15mm Flat Head	500g cardboard packs x 10	5kg
OSNG			1kg cardboard packs x 10	10kg
TPOSNG			5kg trade pack x 1	5kg
OSNBCI/SS	S316L Stainless Steel		500g clamshell pack x 1	500g

IMPORTANT:

READ THIS DATASHEET IN CONJUNCTION WITH BRACING DESIGN GUIDE AND REFER TO ESSENTIAL NOTES AND GENERAL NOTES.

INSTALLATION – AS1684 TYPE A BRACING UNIT

Strap Brace/Speedbrace Type A Unit (Racking Capacity = 1.5 kN/m)

This bracing unit comprises one section of the wall, with cross-over braces of Pryda Strap Brace or Pryda Speedbrace as shown below. The minimum recommended Strap Brace size (SB083) fully complies with AS1684.2:2010 and AS1684.3:2010 specifications. Maximum wall height in AS1684 is 3.0 m (except at gable or skillion ends). Design capacity is 1.5 kN/m for wall heights up to 2.7 m and 1.35 kN/m for 3.0 m height.

WALL HEIGHT (m)	BRACING CAPACITY (KN) FOR BRACING LENGTH (M)									
	1.8	1.9	2.0	2.1	2.2	2.3	2.4	2.5	2.6	2.7
2.7	2.7	2.9	3.0	3.2	3.3	3.5	3.6	3.8	3.9	4.1
3.0	2.4	2.6	2.7	2.8	3.0	3.1	3.2	3.4	3.5	3.6

Note: For walls higher than 2.7 m, reduce the bracing unit's capacity in inverse proportion to the wall height, eg, for 3.6 m walls, take $2.7/3.6 = 0.75$ times the capacity for 2.7 m height. Use galvanised Pryda Timber Connector Nails, code OSNG, size 35 x 3.15 mm.

RACKING CAPACITY	
SB083 - 30 x 0.8mm Strap Brace	1.5 kN/m for wall heights up to 2.7m
	1.35 kN/m for wall heights up to a maximum of 3.0m

STEP 1

STEP 2

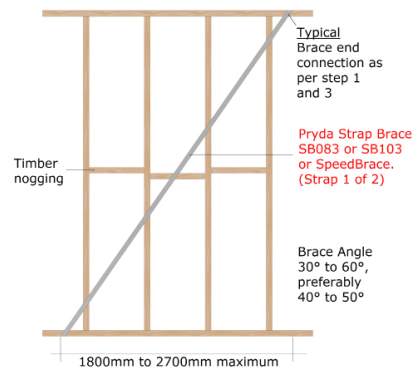
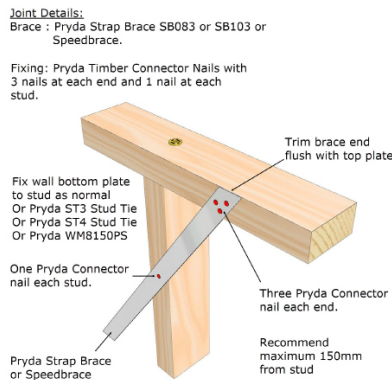

- Ensure wall panel is straight/plumb
- Fix Strap Brace to top plate as per detail above

- Lay Strap Brace at approximately 45° (Maximum 60°, minimum 30°)
- Cut the Strap Brace to length

STEP 3

STEP 4

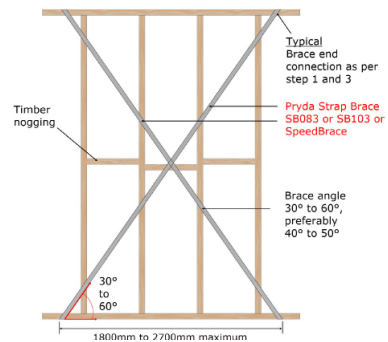
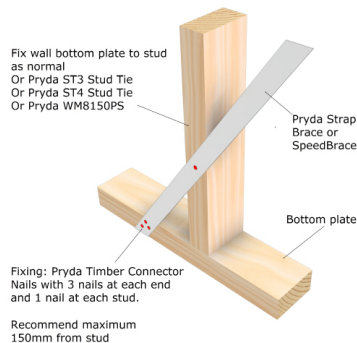

- Fix second end in same manner as the top plate

- Repeat steps 1-3 for the second length of strap, to form the cross brace
- Ensure the frames are fixed down to the underlying structure prior to tensioning the braces
- Fit 1 tensioner per strap, facing into frame so it won't get in the way of plasterboard. Tighten until taut.

INSTALLATION – AS1684 TYPE B BRACING UNIT

Type B Unit (Racking Capacity = 3.0 kN/m)

This Type B bracing unit uses Pryda Strap Brace (SB103) or Pryda Speedbrace, a steel brace thicker than the one used for Type A units. Note: Pryda Strap Brace (SB083) may also be used provided the below table values are reduced by 20%. Maximum wall height in AS1684 is 3.0 m (except at gable or skillion ends). Design capacity is 3.0 kN/m for wall heights up to 2.7 m and 2.7 kN/m for 3.0 m height

WALL HEIGHT (m)	BRACING CAPACITY (KN) FOR BRACING LENGTH (M)									
	1.8	1.9	2.0	2.1	2.2	2.3	2.4	2.5	2.6	2.7
2.7	5.4	5.7	6.0	6.3	6.6	6.9	7.2	7.5	7.8	8.1
3.0	4.9	5.1	5.4	5.7	5.9	6.2	6.5	6.8	7.0	7.3

Note: For walls higher than 2.7 m, reduce the bracing unit's capacity in inverse proportion to the wall height, eg, for 3.6 m walls, take $2.7/3.6 = 0.75$ times the capacity for 2.7 m height. Use galvanised Pryda Timber Connector Nails (OSNG) size 35 x3.15 mm.

RACKING CAPACITY	
SB103 - 30 x 1.0mm Strap Brace	3.0 kN/m at up to 2.7m height
	2.7 kN/m up to a maximum of 3.0m high
Reduced Racking Capacity for SB083 30 x 0.8mm Strap Brace reduced by 20%	2.4 kN/m at up to 2.7m height
	2.1 kN/m up to a maximum of 3.0m high

STEP 1

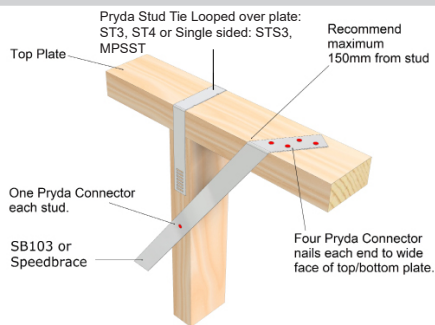

- Ensure wall panel is straight/plumb
- Fix Strap Brace to top plate as per detail above

STEP 2

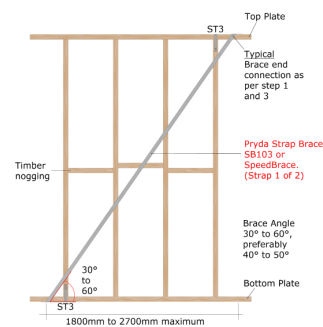

- Lay Strap Brace at approximately 45° (Maximum 60°, minimum 30°)
- Leaving enough length to wrap under the bottom plate, cut the Strap Brace to length

STEP 3

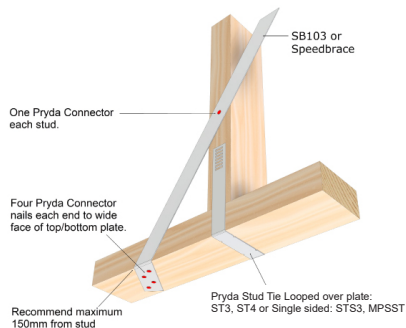

- Fix second end in same manner as the top plate

STEP 4

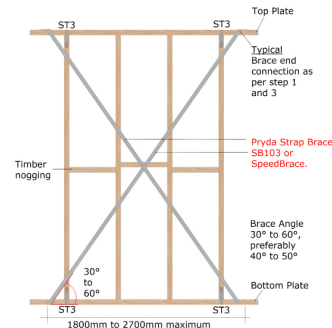

- Repeat steps 1-3 for the second length of strap, to form the cross brace
- Ensure the frames are fixed down to the underlying structure prior to tensioning the braces
- Fit 1 tensioner per strap, facing into frame so it won't get in the way of plasterboard. Tighten until taut.

FASTENING STRAP BRACE

BUILD WITH CONFIDENCE

WHERE POSSIBLE, HAND NAILING WITH PRYDA TIMBER CONNECTOR NAILS IS ALWAYS PREFERRED, WHY?

- Pryda Timber Connector Nails are forged in one piece, unlike clouts that are two pieces soldered together, meaning the head can pop off
- Pryda Nails are the correct diameter, ensuring a tight fit in prepunched holes = a stronger connection
- Design values and testing have all been conducted using Pryda Timber Connector Nails
- Hand hammered nails ensure correct nail positioning and drive depth (not driven to shallow or too deep)

USING PASLODE MACHINE DRIVEN NAILS

Where appropriate, Paslode Machine Driven Nails listed below may be used instead of the specified 35 x 3.15mm Pryda Timber Connector Nails to fix Pryda connectors provided that:

- There is one additional nail per connection than specified in the bracing details (eg. 2 instead of 1, 3 instead of 2, 5 instead of 4 etc.)
- Machine driven nails are driven at nail spacings and edge distances similar to the hole pattern, ensuring that these nails are not:
 - Driven into the holes
 - Located not closer than 5mm from the edge of a hole
 - Grouped together
 - Within 10mm from the edge

Screw hardened, electro galvanised Paslode nails that are appropriate include:

- Duo-Fast C SHEG 32 x 2.3 (D40810)
- Paslode 32 x 2.5mm (B25110)
- Duo-Fast 32 x 2.5mm (D41060)
- Pas Coil 32 x 2.5 SHEG 2 Pack (B25250)
- Impulse 32 x 2.5 SHEG (B40020)

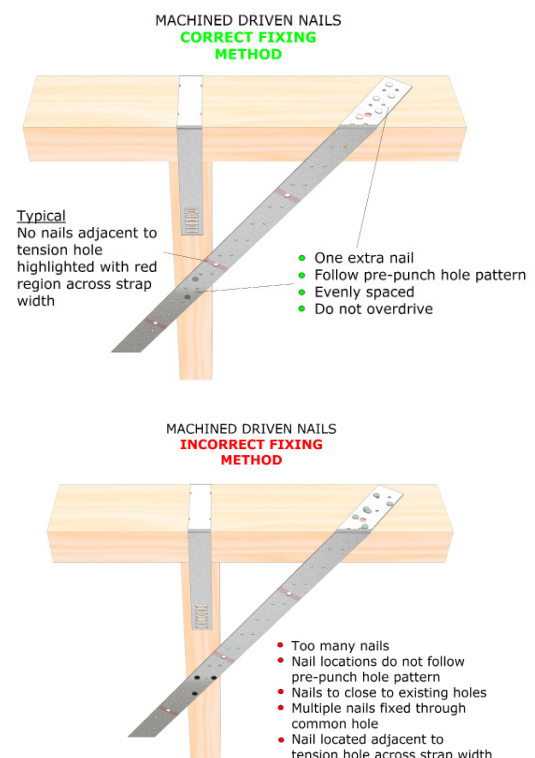

EXTREME CARE MUST BE TAKEN WHEN USING MACHINE DRIVEN NAILS AS THE PREVAILING INSTALLATION PRACTICES TEND TO INHIBIT COMPLIANCE WITH THE ABOVE REQUIREMENTS.

STRAP BRACE TIPS

1. Larger holes are only for tensioners, do not use them for nails
2. Do not over tension Strap Bracing as this can both reduce the capacity of the unit and bring walls out of plumb
3. Ensure nails are at least 10mm away from timber end or edges to prevent splitting
4. Ensure Strap Brace is tensioned prior to nailing to studs/trusses
5. Keep wall bracing angles within 30° to 60° and roof angles between 30° to 45° or the brace will not be compliant
6. Fix Strap Brace to the Bottom Plate before standing wall
7. Avoid having the centre of the opposing brace located over a stud or a nog as this can cause a bump in the plasterboard

NARROW BRACING UNITS

Pryda has developed the Pryda Wall Truss Brace (PWTB) to cater for narrow wall lengths, adopting a similar profile to a floor truss. Three types of units are available, PWTB1/PWTB2 to resist up to 5.0 kN/m and PWTB3 to resist up to 14.0 kN/m racking loads. For detailed information on the PWTBs, refer Design Guide on Pryda Wall Truss Brace.

Also available is a series of Narrow Bracing Units using Strapbrace/Speedbrace. Details of these units are available in a separate publication titled Pryda Design Guide for Narrow Wall Bracing Units.

PRYDA WALL TRUSS BRACE (PWTB) FOR NARROW WALL BRACING APPLICATIONS

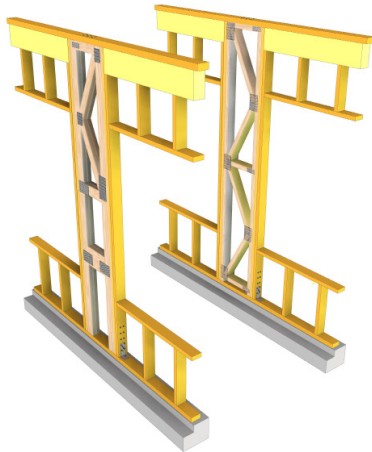

NARROW BRACING UNIT

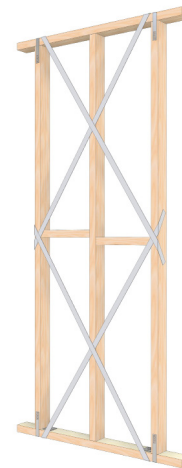

LOOKING FOR MORE DETAILED DESIGN VALUES?

SEE OUR BRACING DESIGN GUIDE AVAILABLE AT [PRYDA.COM.AU](https://www.pryda.com.au)

TECHNICAL INFORMATION

Pryda's recommendations for materials, installation and design loads are given in the following topics.

Materials

All Pryda bracings are manufactured from G300 -Z275 ZincForm® steel or equivalent for high strength and corrosion resistance in normal, interior uses. The Pryda Bracing products included in these units are:

BRACE PRODUCT		
Mini Brace	18 x 16 x 1.2 mm Angle Brace	MB36, MB42, MB48
Maxi Brace	20 x 18 x 1.2 mm Angle Brace	AB36, AB42, AB48
SpeedBrace	37 x 1.0 mm	SDB36, SDB40, SDB50, SDB60
Strap Brace	30 x 0.8 mm, 30 x 1.0 mm, 32 x 1.2 mm	SB083, SB103, SB123

Warning: For the construction of bracing units don't use Hoop Iron and beware of 0.6 mm thickness (or thinner) non-engineered bracing. The latter material may be offcuts of Zinalume or Colorbond which are roofing materials having little or none of the sacrificial protection to cut edges which is a feature of the Galvabond (or equivalent) material used for Pryda products. This protection is required for good corrosion resistance in contact with mortar.

All nails used for bracing units must be hand-hammered galvanised 35 x 3.15 mm Pryda Timber Connector Nails (OSNG). Pryda will not support the use of other nails unless they meet the requirements for machine driven nails in page 3.

Design Capacities

Pryda tests and computations have established the following Limit State Design capacities for Pryda bracings.

For the brace to develop tabulated tension or compression capacities, it must be anchored adequately at each end. In the case of Speedbrace or Strap Brace product, it is necessary to bend the brace around the anchor points to achieve the designated tension capacities. Angle Braces on the other hand are often governed by the end fixing capacity (nail capacities) as they cannot be bent at anchor points.

Tension Capacities

CODE	CROSS SECTION	DESIGN TENSION CAPACITY (ΦNJ) KN
ANGLE BRACE (MINI AND MAXI BRACE)		
MB	18 x 16 x 1.2 mm	7.8
AB	20 x 18 x 1.2 mm	9.5
SPEEDBRACE		
SDB	37 x 1.0 mm	8.7
STRAP BRACE		
SB082	25 x 0.8 mm	3.5
SB083	30 x 0.8 mm	5.2
SB103	30 x 1.0 mm	6.8
SB123	32 x 1.2 mm	9.4

Compression Capacities

STUD SPACING	MAXI BRACE DESIGN COMPRESSION CAPACITY (ΦNJ) (KN)	
(mm)	Parallel to Brace	45o
450	3.7	2.6
600	2.7	1.9

Note: As noted previously the design capacity of Angle Brace is limited by the number of nails at the ends. Using 35 x 3.15 mm Pryda Timber Connector Nails, the wind capacity will be limited to 1.8 kN (2 nails) or 2.8 kN (3 nails) in JD4 timber.

TECHNICAL INFORMATION

Fixing at the Top of Internal Bracing Units

At the top of internal bracing units, the wall must be fixed to the roof structure in order to transfer wind load from the roof to the walls – see Clause 8.3.6.9 of AS1684:2010 Part 2. Without this connection, these bracing units cannot act as part of the bracing system. For trussed roofs, the connection must allow a clearance for settlement of the trusses over time. The connection must have a shear capacity at least equivalent to the bracing capacity of the unit. Table 8.22 specifies suitable connections and their shear capacities.

Pryda has introduced a new product Pryda Shear Connectors (PSC) to help builders meet the requirements of AS1684. Complete details on the PSC is given in pages 14 and 15.

Fixing at the Bottom of Bracing Units (Tie-downs) – AS1684:2010 Requirements

AS1684-2010 Residential Timber Framed Construction - Parts 2, 3 and 4 specify requirements for bracing of walls (Section 8) which include fixing at the bottom of bracing walls (aka: bracing units, bracing panels).

Fixing Requirements for Bracing Walls- Simplified Interpretation. The following table interprets Clause 8.3.6.10 of AS1684:2010.

CASE	BRACING WALL TYPES	FIXING REQUIREMENTS – GENERAL
1	Nominal bracing	Nominal fixing only – as per Table 9.4
2	Up to 3.4 kN/m capacity, included in Table 8.18	Nominal fixing only – as per Table 9.4 (see note below)
3	3.4 to 6.0 kN/m capacity, included in Table 8.18	As specified in Table 8.18
4	3.4 to 6.0 kN/m capacity, not included in Table 8.18	Determine uplift force from Table 8.23 and fixing detail from Table 8.24 or other tie-down fixing specification – or: - refer Ramset™ Ankascrews™ capacities in page 15 - use engineering design:
5	6.0 kN/m or greater capacity, included in Table 8.18	As specified in Table 8.18. Where intermediate bottom plate fixings are not specified in Table 8.18, additional intermediate bottom plate fixings of minimum 1/ M10 bolt or 2/No. 14 Type 17 screws at maximum 1200 mm centres are required.
6	6.0 kN/m or greater capacity, not included in Table 8.18	As for case 4 above, with intermediate fixings

NOTES:

- Table 8.18 of AS1684.2:2010 nominates that bracing systems with a racking capacity of 3.4 kN/m require only nominal fixing of the bottom plate to the concrete slab/floor joists. This reduced requirement has been established from whole house testing programs, along with post-wind damage assessments of the performance of bracing in housing.
- The nominal fixing requirement for bottom plate to concrete slab as per Table 9.4 is “One 75 mm masonry nail (hand-driven at slab edge), screw or bolt at not more than 1200 mm centres”

Useful AS1684:2010 Clauses and Tables on Wall Bracing

1. Clause 8.3.6.10 Fixing of bottom of bracing walls
2. TABLE 8.18 STRUCTURAL WALL BRACING
3. TABLE 8.23 UPLIFT FORCE AT ENDS OF BRACING WALLS
4. TABLE 8.24 FIXING OF BOTTOM OF BRACING WALLS
5. TABLE 9.4 NOMINAL FIXINGS FOR TIMBER MEMBERS

AS1684 is subject to amendments and fabricators are advised to keep informed of amendments.

PRYDA SHEAR CONNECTORS (PSC)

FEATURES AND BENEFITS

SMART: Allows vertical movement of trusses while still transferring racking loads

FAST: Can be machine nailed

VERSATILE: Suitable for walls both perpendicular and parallel to the truss

SPECIFICATIONS

PRODUCT CODE	PSC
STEEL	G300
THICKNESS	1.0mm
CORROSION RESISTANCE	Z275
FASTENERS	Pryda Timber Connector Nails 35 x 3.15mm OR Paslode machine driven nails (Refer to using Paslode Machine Driven Nails)
SIZE	30mm wide X 300mm (flat length)
QUANTITY	200 per carton

Smart method of transferring racking loads into non-load bearing walls.



AS1684 COMPLIANT

- Transfer of racking loads as per Clause 8.3.6.9, part 2
- Designed and tested in accordance with Australian standards
- Minimum G300 Z275 Galvanised Steel

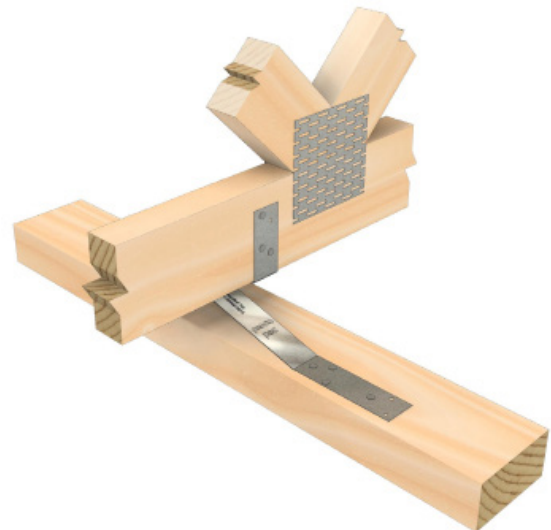

APPLICATION & FEATURES

Pryda Shear Connectors (PSC) are used to transfer racking loads from the ceiling diaphragm to non-load bearing bracing walls. These connectors allow vertical movement of trusses (to release creep deflection) and ensures that truss camber dissipation is uninhibited by over-driven nails.

PSC are fixed to top of bracing walls and can be used as a direct substitute for a pair of nail fixed timber blocks as specified in Table 8.22 AS 1684.2:2010 and AS1684.3:2010.

Table A provide design information on how PSC may be specified.

PSC should always be used in pairs as illustrated.

INSTALLATION

1. All trusses are to be installed in accordance with the requirements of AS4440.
2. Discard any damaged product.
3. It is preferable (but not essential) to fix the Pryda Shear Connectors (PSC) after the roof cladding has been fixed and prior to the application of the ceiling material.
4. The PSC are to be installed in opposing pairs on the same bottom chord of a truss.
5. Ensure the connectors are located adjacent to each other and directly over the internal, non-load bearing bracing wall to which they are to be fixed.
6. Fix each connector to the truss bottom chord with the specified number of nails below so that the connector is flush up against the vertical face and under side of the truss bottom chord.
7. Ensure the long leg of each connector passes under the bottom chord and is located directly over the underlying top plate.
8. Press vertically downwards on the free end of the long leg of the connector until it contacts the top face of the underlying top plate.
9. Fix the long leg down to the underlying top plate with the specified number of nails.
10. Repeat where marked on truss & wall frame layout.

(A) TRUSSES PERPENDICULAR TO WALL

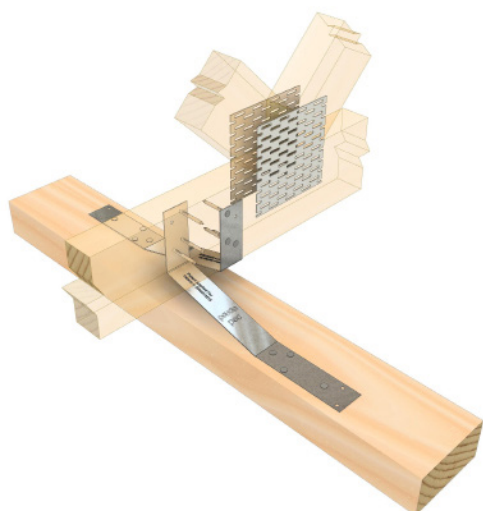

(B) TRUSSES PARALLEL TO WALL

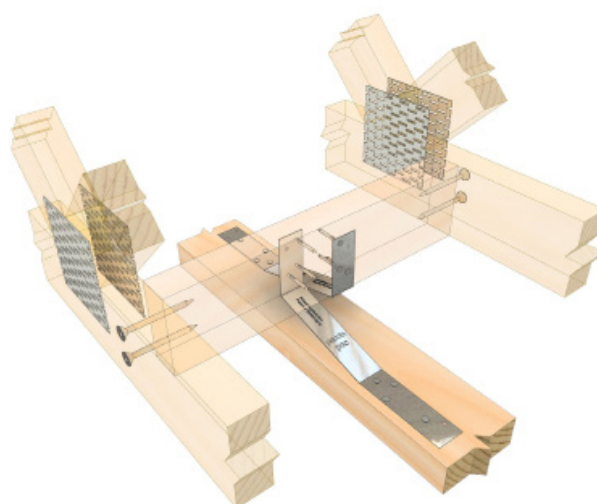

IMPORTANT:

READ THIS DATASHEET IN CONJUNCTION WITH PRYDA BRACKETS & FIXES GUIDE AND REFER TO ESSENTIAL NOTES AND GENERAL NOTES.

INSTALLATION

BRACING TYPE	WALL LENGTHS (MM)	NO. OF PAIRS OF PRYDA SHEAR CONNECTORS	NO. OF NAIL FIXING ONTO TOP PLATE PER CONNECTOR*	FIXING TO TRUSS PER CONNECTOR
TYPE A 1.5kN/m	1800	1	4	3
	2400	1	4	3
	2700	1	5	3
TYPE B 3.0kN/m	1800	2	4	3
	2400	2	4	3
	2700	2	5	3
NARROW WALL BRACING 6.0kN/m	600	1	4	3
	900	2	4	3
	1200	2	4	3
	1500	2	5	3

*If nails are machine driven using 32 x 2.3 Duo-Fast SHEG or equivalent, provide one additional nail to the table values and ensure nails are driven away from holes.

Note: When specifying requirement for non-standard braced wall lengths, assume a pair of PSC (with 5 nails) is capable of resisting a maximum 2700 mm (for 1.5 kN/m capacity) and 1500 mm (for 3.0 kN/m capacity) wall lengths.

FASTENING PRYDA SHEAR CONNECTORS

BUILD WITH CONFIDENCE

WHERE POSSIBLE, HAND NAILING WITH PRYDA TIMBER CONNECTOR NAILS IS ALWAYS PREFERRED, WHY?
<ul style="list-style-type: none"> • Pryda Timber Connector Nails are forged in one piece, unlike clouts that are two pieces soldered together, meaning the head can pop off • Pryda Nails are the correct diameter, ensuring a tight fit in prepunched holes = a stronger connection • Design values and testing have all been conducted using Pryda Timber Connector Nails • Hand hammered nails ensure correct nail positioning and drive depth (not driven too shallow or too deep) • The corrosion resistance and material specification of Pryda Nails is known and can be certified

USING PASLODE MACHINE DRIVEN NAILS

Where appropriate, Paslode Machine Driven Nails listed below may be used instead of the specified 35 x 3.15mm Pryda Timber Connector Nails to fix Pryda connectors provided that:

- There is one additional nail per connection than specified in the bracing details (eg. 2 instead of 1, 3 instead of 2, 5 instead of 4 etc.)
- Machine driven nails are driven at nail spacings and edge distances similar to the hole pattern, ensuring that these nails are not:
 - Driven into the holes
 - Located not closer than 5mm from the edge of a hole
 - Grouped together
 - Within 10mm from the edge

Screw hardened, electro galvanised Paslode nails that are appropriate include:

- Duo-Fast C SHEG 32 x 2.3 (D40810)
- Paslode 32 x 2.5mm (B25110)
- Duo-Fast 32 x 2.5mm (D41060)
- Pas Coil 32 x 2.5 SHEG 2 Pack (B25250)
- Impulse 32 x 2.5 SHEG (B40020)

TIE-DOWN ANCHORS

Suitable tie-down anchors for wall bracing units are:

APPLICATION	SUITABLE ANCHORS
External walls	Ramset™ AnkaScrews™ or equivalent Ramset™ Chemset™ Injection 100 and 800 series or equivalent Ramset™ Chemset™ Spin Capsules or equivalent
Internal walls	Ramset™ AnkaScrews™ and other Chemset™ Anchors as above Ramset™ Dynabolt™ Anchors or equivalent Ramset™ Trubolt™ Anchors or equivalent

For Design capacities and installation instructions on the above anchors, visit Ramset at www.ramset.com.au or contact Ramset direct. Ramset™ AnkaScrews™ M12 x100 (AS12100H) is available from Pryda.

DESIGN CAPACITIES OF RAMSET™ ANKA SCREWS™

Ramset™ AnkaScrews™ through 35 mm thick bottom plates

PART CODE	ANCHOR SIZE	EFFECTIVE ANCHOR DEPTH FOR 35 MM BOTTOMPLATE(NOMINAL)	UPLIFT CAPACITY (ΦNJ) (KN)			MINIMUM CONCRETE THICKNESS (MM)
			EXTERNAL WALLS		INTERNAL WALLS	
			70 MM	90 MM		
AS12100H	M12 x 100	60	5.2	5.8	10.4	85
AS12150H	M12 x 150	110	13.1	14.3	26.1	135

Ramset™ AnkaScrews™ through 45 mm thick bottom plates

PART CODE	ANCHOR SIZE	EFFECTIVE ANCHOR DEPTH FOR 35 MM BOTTOMPLATE(NOMINAL)	UPLIFT CAPACITY (ΦNJ) (KN)			MINIMUM CONCRETE THICKNESS (MM)
			EXTERNAL WALLS		INTERNAL WALLS	
			70 MM	90 MM		
AS12100H	M12 x 100	50	3.9	4.3	7.8	75
AS12150H	M12 x 150	100	11.3	12.5	22.6	125

Design capacities in the above tables are based on:

- Minimum Grade 20 concrete.
- Minimum anchor edge distances – external walls of 35 mm for 70 mm wall frames, 45 mm for 90 mm frames.
- Minimum anchor edge distances – internal walls = 120 mm.
- Washers of sufficient capacity, as tabulated in the following table, must be installed between the anchor head and bottom wall plate.
- The final tie-down capacity is limited by the minimum of Anchor and the washer capacities.

Minimum Washer Sizes for Tie-down Anchors

SQUARE WASHER SIZE (MM)	ROUND WASHER SIZE (MM)	WASHER TYPE AND PRYDA CODE	CAPACITY (ΦNJ) (KN) FOR JOINT GROUP	
			JD5	JD4
50 x 50 x 3.0	55 dia x 3.0	Standard OW12/56S	8.4	10.5
65 x 65 x 5.0	75 dia x 5.0	Heavy Duty OW12/65S	20.8	26.1

APPENDIX

This appendix to the Pryda Bracing Guide provides information and recommendations on design, construction and engineering matters related to the bracing of walls in timber framed construction. It has been prepared by Pryda engineers in response to questions from Pryda licensed frame manufacturers.

How Does Bracing Work?

Bracing is an essential part of any building. To design and install bracing that “works” (is effective in resisting the loads caused by the wind), it is essential to understand how bracing works. Otherwise serious building problems can arise. The following topics are intended to simply explain the basic concepts of bracing systems.

Bracing is a System

It is most important to realise that Pryda bracings and other types of bracings “work” as part of a bracing system which comprises:

1. The bracing.
2. The fixing of the bracing to the frame, especially the end fixing (ie, nails).
3. Any straps required as part of the bracing unit.
4. The parts of the frame to which the bracing is fixed, ie, wall plates, studs, including any joints in the wall plates (see note below).
5. The connection of the braced part of the frame to the supporting structure, eg, fixing of the bracing unit to the floor system.
6. The parts of the building which transmit the applied wind load down to the footings and ground.

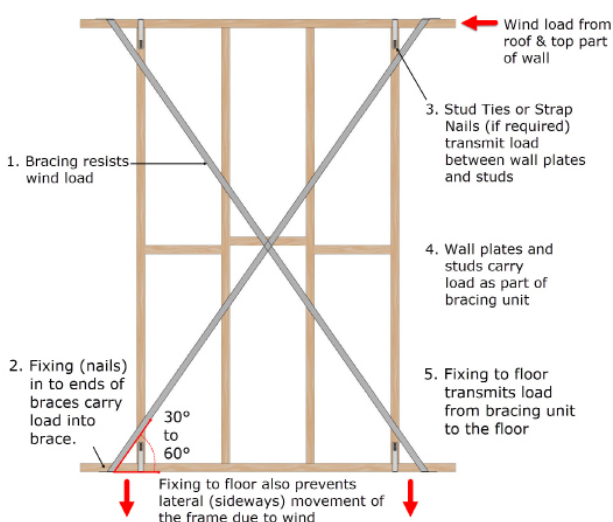

These elements of the bracing system are like links in a chain and all must be strong enough to take the wind load or the whole system may collapse. For example, if the braces are not adequately fixed or if the bracing unit is not properly tied down, the bracing system may fail.

Bracing Must Work in All Directions

Because wind can blow in any direction, the bracing system must also be effective in all directions. Therefore, bracing must be installed in walls along the length of the building and walls across the width - as well as in the roof. Also, in any wall diagonal bracing should be at both diagonals if possible, to resist the wind in both directions along the wall.

The external corners of the building should be braced to avoid distortion of the building under wind at an angle to wall directions.

Note: As far as is practicable, a unit should be placed at each corner of the exterior walls. The other units are to be distributed fairly evenly throughout the interior walls. AS1684 clause 8.3.6.9 requires that interior bracing walls be fixed to the ceiling or roof frame to transfer shear loads- see Table 8.22 of the code.

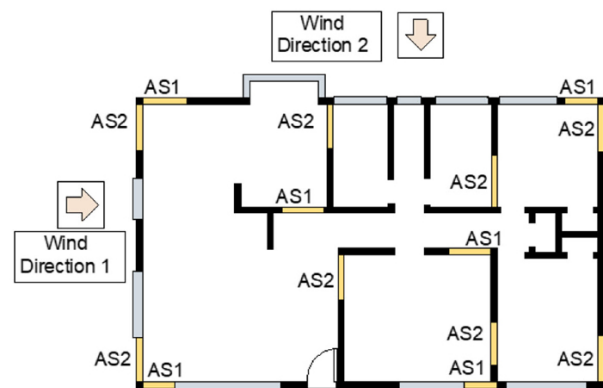

Bracing Must Be Spread Throughout the Whole Building

Wind can, of course, blow on any part of the building, including the roof. Bracing must therefore, as much as possible, be installed throughout the whole building to provide adequate wind resistance in all parts of the frame. Bracing in internal walls transfers to the floor structure not only internal wall pressure, but also horizontal wind load on the roof. That is one reason why internal bracing units must be connected to the roof.

APPENDIX

The Higher the Building, the Greater the Wind Load

The force in the bracing system for the lower storey of two storey buildings is much greater than in the upper storey or in a single storey building due to:

1. The wind causing the load on the lower storey blows on 1 ½ storeys plus the roof, compared to ½ storey plus the roof.
2. The speed of the wind, and therefore its force, increases with height above ground. For example, the wind force at 10 m height is rated as 18% greater than at 4 m.

Therefore, bracing in the lower storey of two storey constructions is required to be about 60% stronger than for the upper storey or single storey. Two storey constructions with a substantial area of exterior windows or doors in the lower storey, especially with open-plan areas, can be impossible to adequately brace by conventional methods; special engineering design and/or changes to the layout may be required.

Single Storey or Upper Storey Walls

Area of elevation (causing load on bracing) is the vertical area above mid-height of the wall frame.

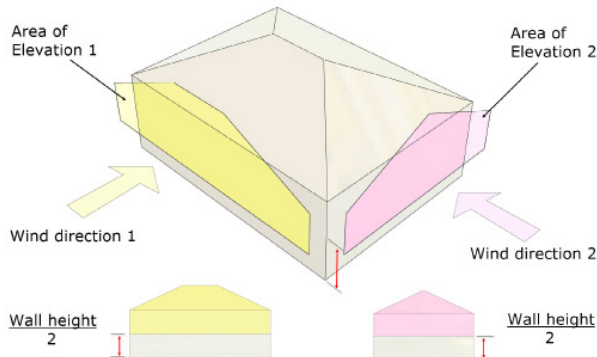

Lower Storey Walls

Area of elevation (causing load on bracing) is the vertical area above mid-height of the lower wall frame.

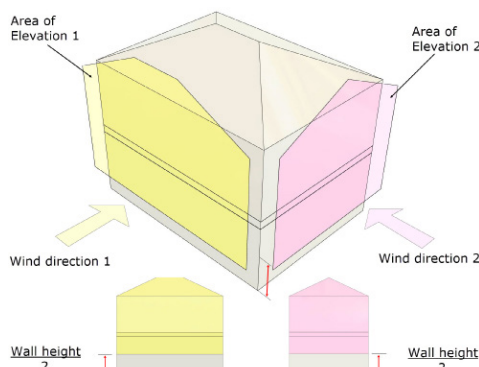

Bracing Must Be Straight and Not Cut

Bracing must be straight (not bent) and not cut as any bends, kinks, distortions or any cutting can weaken the bracing substantially. Do not cross-over Angle Brace (Mini or Maxi Brace).

Keep Nails Away From Edges and Ends of Timber

Nails driven too close to the edge or ends of studs or wall plates can cause splitting of the timber and therefore, a substantial loss of strength in the joints. Ideally, maintain the recommended minimum end and edge distances.

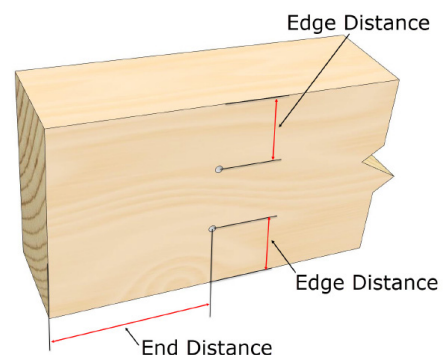

End distance - 20D for nails

Edge distance - 5D nails where D = diameter of nails

Layout & Spacing of Bracing Units

To locate the wall bracing units:

- On the building plan drawing, determine the lengths of external and internal walls available for installation of bracing units.
- In accordance with AS1684.2:2010:
 - (a) Locate a bracing unit near each corner of the building.
 - (b) Distribute bracing units as evenly as possible throughout the building.

Note: Maximum spacing between units is 9.0 m for N1 and N2; see AS1684.2:2010 Cl. 8.3.6.7 otherwise.

APPENDIX

Locating a Bracing Unit Near Each Corner of the Plan

Clause 8.3.6.6 Location and distribution of bracing of AS1684 Part 2 specifies: “Bracing shall initially be placed in external walls and where possible at the corners of the building.” Figure 1. below is an example of this first step.

Note that in the bottom wall at the right corner, there isn't enough wall length at the corner to fit in a bracing unit. Consequently, a unit is located in the closest available location, to the left.

Figure 1. Bracing Location – Step 1

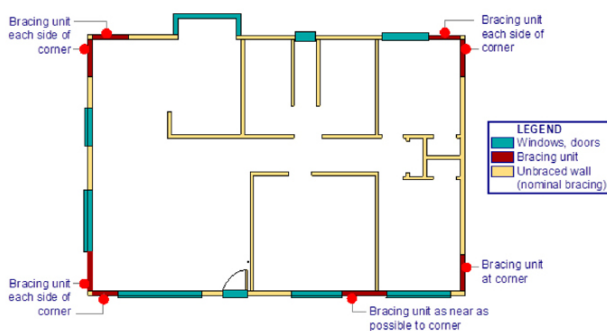

Distributing Bracing Units as Evenly as Possible Throughout the Building

Clause 8.3.6.6 of AS1684 Part 2 also specifies: “Bracing shall be approximately evenly distributed and shall be provided in both directions”. Figure 2. below shows even distribution of bracing units throughout the internal walls in both directions.

Figure 2. Bracing Location – Final Step

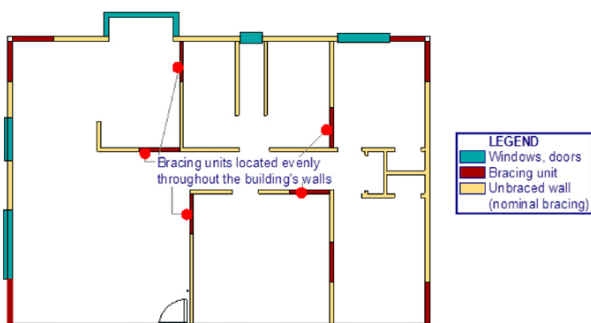

Design of “Difficult” Buildings

Some timber framed buildings are “difficult” to adequately brace because:

1. They do not have enough braceable wall lengths to include all the required bracing units. *Note: This is due to the presence of many window or door openings and particularly common in two-storey houses with large open areas in the ground floor.*
2. The spacing between braceable wall lengths is greater than the specified maximum.

For such buildings, Clause 8.3.6.7 of AS1684 Part 2 specifies: Where bracing cannot be placed in external walls because of openings or the like, a structural diaphragm ceiling may be used to transfer racking forces to bracing walls that can support the loads.

Parallel chord trusses installed in the horizontal plane, commonly known as “Wind Trusses” are sometimes adopted to facilitate this. Alternatively, wall frames may be designed for portal action.

Structural ceilings, wind trusses and portal frames require engineering design. Advice can be obtained from Pryda engineers or a consulting engineer.

Guide to Handling Wall Bracing Jobs

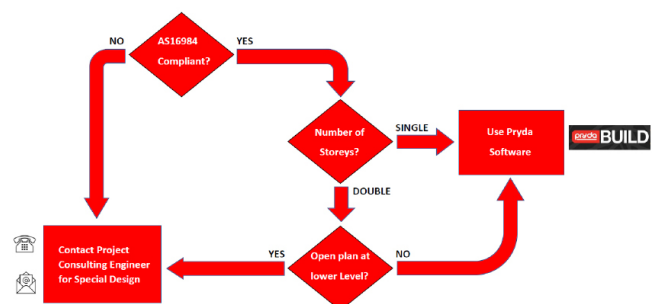

www.pryda.com.au www.pryda.co.nz

For more information call 1300 657 052 (Australia), 0800 88 22 44 (New Zealand) or email info@pryda.com.au